

Hydraulic Link Clamp

- Model LKA
- Model LKC
- Model LKW
- Model LJ/LM
- Model TMA-2
- Model TMA-1



Compact Cylinder with Built-in Link Mechanism

Link design is not required.

Action Description

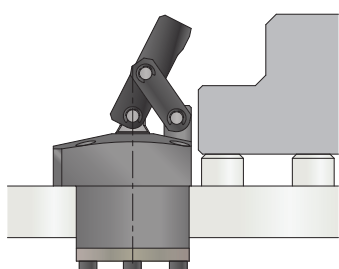

Released State

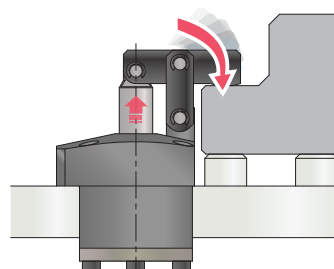

Locked State

Application Examples

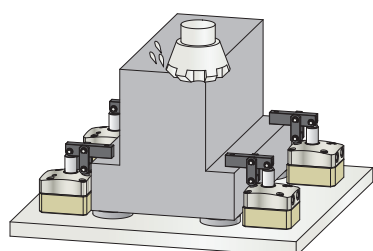

Machining

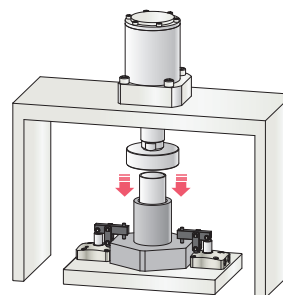

Press Fitting

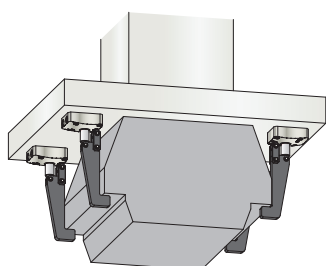

Transfer • Gantry Loader

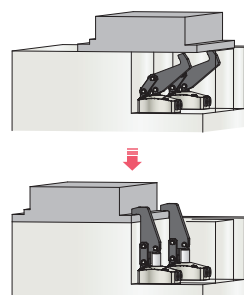

Interference Prevention



Link Clamp Quick Change Lever Option A

Model **LKA-A / LKC-A / LKW-A / LJ-A / LM-A**

Quickest Lever Setup Time Possible by One Bolt Exchange

● Quick Change Lever Option A is Suitable for Frequent Lever Change

When changing a standard lever, a special tool is required to install/remove a snap ring which fixes the lever pin and rod pin. Installation/Removal of the snap ring takes time and there is a possibility of deformation/loss of the snap ring.

Option A, however, does not require snap rings or special tools, but only one wrench and bolt which is suitable especially for frequent lever change.



● Lever Removal Procedure

Loosen the bolt on the cover top and remove the cover.
(The bolt does not fall from the cover.)

Pull out the rod pin and the lever pin, and remove the cover.

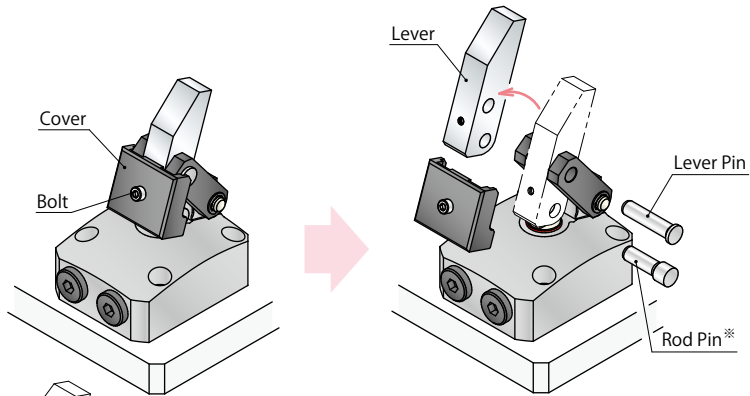

※ Rod pin has thicker flange.

● Lever Installation Procedure

Set another lever and insert the rod pin and the lever pin. (The pins can also be inserted from the other side.)

Set the cover and tighten the bolt.
Lever installation is now completed.

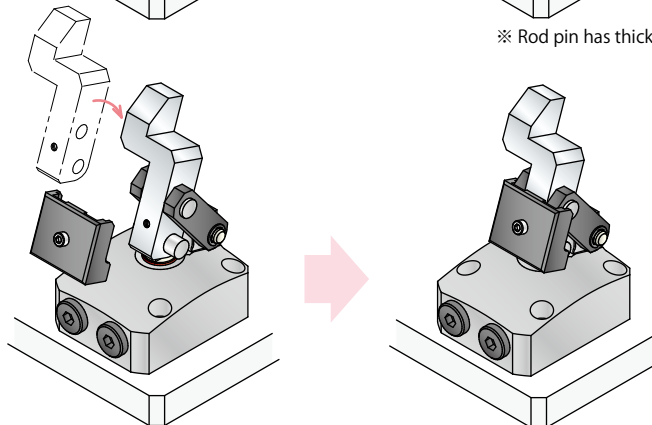

Air Sensing Link Clamp

Model **LKW**

Clamp-unclamp confirmation with built-in air catch sensor for smaller footprint fixtures.

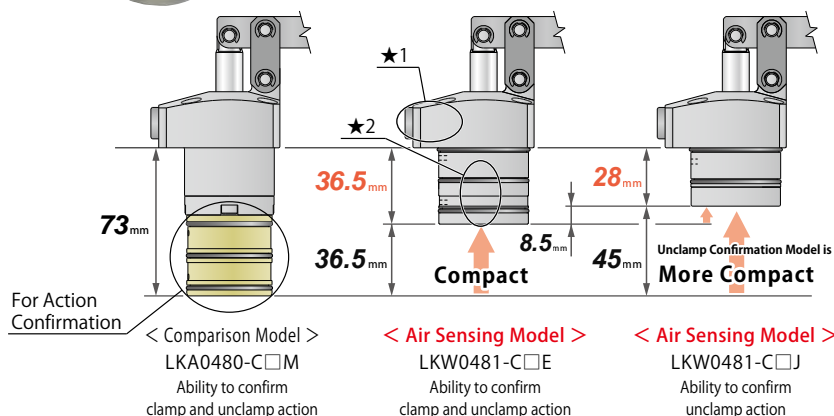

★1
Clamp Confirmation Valve

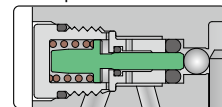

★2
Unclamp Confirmation Valve

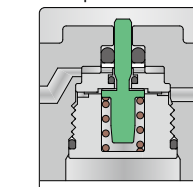

High-Power Series
Pneumatic Series
Hydraulic Series
Valve / Coupler Hydraulic Unit
Manual Operation Accessories
Cautions / Others

Hole Clamp
SFA
SFC

Swing Clamp
LHA
LHC
LHS
LHW
LG/LT
TLA-2
TLB-2
TLA-1

Link Clamp
LKA
LKC
LKW
LJ/LM
TMA-2
TMA-1

Work Support
LD
LC
TNC
TC

Air Sensing Lift Cylinder
LLW

Linear Cylinder / Compact Cylinder
LL
LLR
LLU
DP
DR
DS
DT

Block Cylinder
DBA/DBC

Centering Vise
FVA
FVD
FVC









Control Valve
BZL
BZT
BZX/JZG
BZS

Pallet Clamp
VS/VT

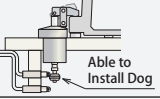
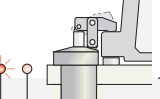
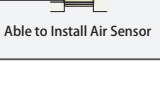

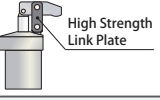
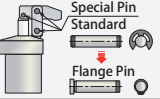



Expansion Locating Pin
VFL/VFM
VFJ/VFK









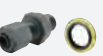

Pull Stud Clamp
FP
FQ

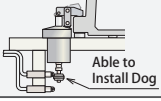
Customized Spring Cylinder
DWA/DWB

Low Pressure Model MAX. 7MPa		 Model LKA → P.611	 Model LKC → P.637	 Model LKW → P.651
Classification		Double Action	Double Action Compact	Double Action Built-in Sensing Valve
Operating Pressure Range		0.5 ~ 7MPa	0.5 ~ 7MPa	0.5 ~ 7MPa
Standard Model		External Dimensions → P.623	External Dimensions → P.645	—
Action Confirmation	Double End Rod Option for Dog  Able to Install Dog	External Dimensions → P.625	—	—
	Air Sensing Manifold Option 	External Dimensions → P.627	—	—
	Air Sensing Piping Option  Able to Install Air Sensor	External Dimensions → P.629	—	—
	Built-in Sensing Valve Model	—	—	External Dimensions → P.665
Option	Quick Change Lever Option A 	External Dimensions → P.631	External Dimensions → P.647	External Dimensions → P.671
	High Strength Link Plate Option  High Strength Link Plate	Allowable offset increases. (External dimension is the same as standard model.)	Allowable offset increases. (External dimension is the same as standard model.)	Allowable offset increases. (External dimension is the same as standard model.)
	Flange Pin with C-type Circlip  Special Pin Standard Flange Pin	★	★	★
Accessories	Lever 	LZK-L LZK-W → P.636	LZK-L LZK-W → P.650	LZK-L LZK-W → P.674
	Manifold Block 	LZY-MD	→ P.1335	—
	Speed Control Valve Plug 	BZL, BZX, JZG, BZS	→ P.947	

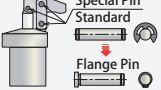
※ Please contact us for detail dimension at ★ part.

High Pressure Model MAX. 35MPa		 Model TMA-2 → P.691	 Model TMA-1 → P.703	 Model TMV-2	
Classification		Double Action	Single Action (Spring Release)	Double Action with Action Confirmation	
Operating Pressure Range		3.5 ~ 35MPa	3.5 ~ 35MPa	3.5 ~ 35MPa	
Accessories	Lever 	LZ-LJ3 LZ-LJ2 → P.702	LZ-LJ3 LZ-LJ2 → P.714	Further information on the website.	
	Manifold Block 	TMZ-2MB → P.1337	TMZ-1MB → P.1337		
	Speed Control Valve Plug 	BZT, JZG	→ P.947		
	G-Thread Fitting 	G-Thread Fitting (Made by Ihara Science) → P.1351			

Low Pressure Model MAX. 7MPa		 Model LJ/LM → P.675	 Model LKK	 Model LKV
Classification		Single Action (Spring Release)	Double Action 360° Rotatable Lever	Double Action 1-Port Sensing
Operating Pressure Range		2.5 ~ 7MPa	0.5 ~ 7MPa	1 ~ 7MPa
Standard Model		External Dimensions → P.683		
Action Confirmation	Double End Rod Option for Dog  Able to Install Dog	—	Further information on the website.	Further information on the website.
	Air Sensing Manifold Option 	—		
	Air Sensing Piping Option  Able to Install Air Sensor	—		
	Built-in Sensing Valve Model	—		
Option	Quick Change Lever Option A 	External Dimensions → P.685		
	High Strength Link Plate Option  High Strength Link Plate	—		
	Flange Pin with C-type Circlip  Special Pin Standard Flange Pin	—		
Accessories	Lever 	LZ-LJ1, LZ-LJ2 LZK-W → P.688		
	Manifold Block 	LZ-MS → P.1336		
	Speed Control Valve Plug 	BZL, BZX, JZG, BZS → P.947		

※ Please contact us for detail dimension at ★ part.



High-Power Link Clamp Hydraulic Double Action

Model **LKE**

2 sizes smaller with equivalent clamping force. Mechanical lock and hydraulic pressure allow for strong clamping and holding force. Refer to P. 53 for further information.

- High-Power Series
- Pneumatic Series
- Hydraulic Series**
- Valve / Coupler Hydraulic Unit
- Manual Operation Accessories
- Cautions / Others
- Hole Clamp
 - SFA
 - SFC
- Swing Clamp
 - LHA
 - LHC
 - LHS
 - LHW
 - LG/LT
 - TLA-2
 - TLB-2
 - TLA-1
- Link Clamp**
 - LKA
 - LKC
 - LKW
 - LJ/LM
 - TMA-2
 - TMA-1
- Work Support
 - LD
 - LC
 - TNC
 - TC
- Air Sensing Lift Cylinder
 - LLW
- Linear Cylinder / Compact Cylinder
 - LL
 - LLR
 - LLU
 - DP
 - DR
 - DS
 - DT
- Block Cylinder
 - DBA/DBC
- Centering Vise
 - FVA
 - FVD
 - FVC
- Control Valve
 - BZL
 - BZT
 - BZX/JZG
 - BZS
- Pallet Clamp
 - VS/VT
- Expansion Locating Pin
 - VFL/VFM
 - VFJ/VFK
- Pull Stud Clamp
 - FP
 - FQ
- Customized Spring Cylinder
 - DWA/DWB

Hydraulic Double Action Link Clamp

Model TMA-2

High Pressure (3.5 ~ 35MPa)

High Power • Compact Clamp



Index

Hydraulic Link Clamp Digest	P.607
Action Description	P.692
Model No. Indication	P.693
Specifications	P.694
Performance Curve	
• Clamping Force Curve	P.695
• Allowable Offset Graph	P.697
External Dimensions	P.699
Lever Design Dimensions	P.701
Accessories	
• Material Link Lever for TMA	P.702
• Speed Control Valve•Plug	P.947
• Manifold Block (Common Items of Other Models)	P.1337
Cautions	
• Notes for Hydraulic Link Clamps	P.715
• Cautions (Common)	P.1355
• Installation Notes • Hydraulic Fluid List • Notes on Hydraulic Cylinder Speed Control Circuit	
• Notes on Handling • Maintenance/Inspection • Warranty	

● **Action Description**

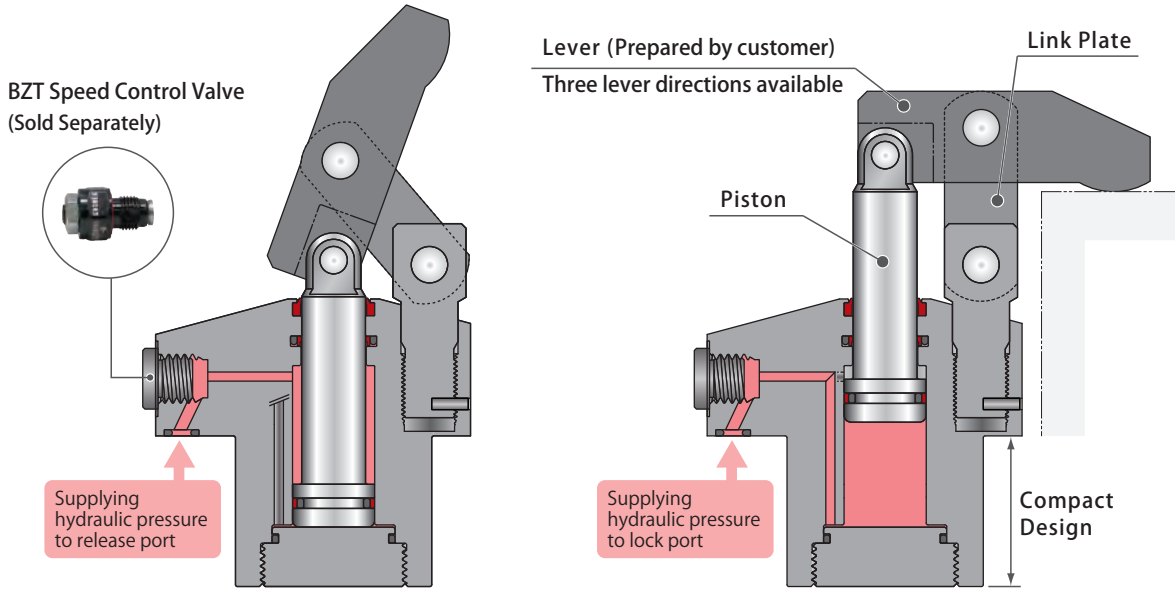

When releasing

Perform the release action by supplying hydraulic pressure to release port.

When locking

Perform the lock action by supplying hydraulic pressure to lock port.

● **Lever in Three Directions Available**

Lever positioning is available in three directions; L: Left, C: Center, R: Right. As seen from the port side.

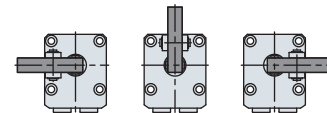

● **Excellent Coolant Resistance**

Our exclusive dust seal is designed to protect against high pressure coolant. It also has high durability against chlorine-based coolant by using a sealing material with excellent chemical resistance.

● **Able to Attach Speed Control Valve Directly**

When fitting the gasket (Piping Option -C), it is able to attach the speed control valve with air venting function. (Speed control valve is sold separately.)

High-Power Series
Pneumatic Series
Hydraulic Series
Valve / Coupler Hydraulic Unit
Manual Operation Accessories
Cautions / Others

Hole Clamp
SFA
SFC

Swing Clamp
LHA
LHC
LHS
LHW
LG/LT
TLA-2
TLB-2
TLA-1

Link Clamp
LKA
LKC
LKW
LJ/LM
TMA-2
TMA-1

Work Support
LD
LC
TNC
TC

Air Sensing Lift Cylinder
LLW

Linear Cylinder / Compact Cylinder
LL
LLR
LLU
DP
DR
DS
DT

Block Cylinder
DBA/DBC

Centering Vise
FVA
FVD
FVC

Control Valve
BZL
BZT
BZX/JZG
BZS

Pallet Clamp
VS/VT

Expansion Locating Pin
VFL/VFM
VFJ/VFK

Pull Stud Clamp
FP
FQ

Customized Spring Cylinder
DWA/DWB

Model No. Indication

Double Action Model

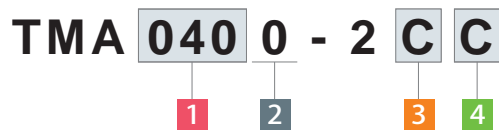

1 Body Size (Clamping Force)

- | | |
|-----------------------------------|-----------------------------------|
| 025 : $\phi D=33\text{mm}$ | 160 : $\phi D=60\text{mm}$ |
| 040 : $\phi D=36\text{mm}$ | 250 : $\phi D=70\text{mm}$ |
| 060 : $\phi D=43\text{mm}$ | 320 : $\phi D=85\text{mm}$ |
| 100 : $\phi D=48\text{mm}$ | |

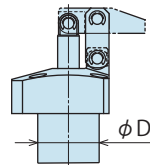

2 Design No.

0 : Revision Number

3 Piping Method

- B** : G Thread Piping Option (No Gasket Port)
- C** : Gasket Option (With G Thread Plug)

※ Speed control valve (BZT-A) is sold separately.
 Please use a meter-in speed control valve for TMA-2.
In case of using Kosmek model, select BZT□-A.
 Refer to P.947 for detail.

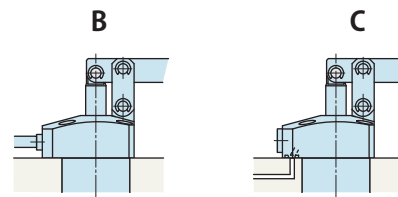

Piping Option
 G Thread
 No Gasket Port

Gasket Option
 With G Thread Plug (able to
 attach Speed Control Valve)
 (Order the valve
 (BZT-A) separately)

4 Lever Direction

- L** : Left
- C** : Center
- R** : Right

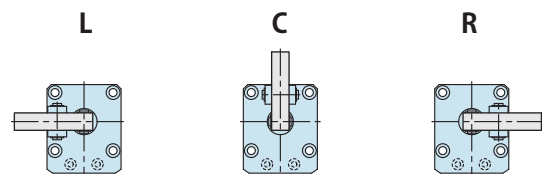

※ The images show the lever direction when the piping port is placed in front of you.

Specifications

Model No.	TMA0250-2□□	TMA0400-2□□	TMA0600-2□□	TMA1000-2□□	TMA1600-2□□	TMA2500-2□□	TMA3200-2□□		
Cylinder Area for Locking	cm ²	1.039	1.539	2.545	3.801	6.158	11.341		
Clamping Force (Calculation Formula) ※1	kN	$F = \frac{1.50 \times P}{L - 16}$	$F = \frac{2.56 \times P}{L - 18.5}$	$F = \frac{4.81 \times P}{L - 21}$	$F = \frac{8.38 \times P}{L - 24.5}$	$F = \frac{16.63 \times P}{L - 30}$	$F = \frac{26.06 \times P}{L - 36}$	$F = \frac{44.91 \times P}{L - 44}$	
Full Stroke	mm	20.5	23.5	26	29.5	35	41	49	
Lock Stroke	mm	17.5	20.5	23	26.5	32	38	46	
Extra Stroke	mm	3	3	3	3	3	3	3	
Cylinder Capacity	Lock	cm ³	2.1	3.6	6.6	11.2	21.6	33.0	55.6
	Release	cm ³	0.5	1.0	2.6	3.7	8.2	7.7	16.2
Max. Operating Pressure	MPa	35.0							
Min. Operating Pressure※2	MPa	3.5							
Operating Temperature	°C	0 ~ 70							
Weight ※3	kg	0.7	0.9	1.3	2.0	3.3	5.1	8.3	

- Notes : ※ 1. F : Clamping Force (kN), P : Supply Hydraulic Pressure (MPa), L : Distance between the piston center and the clamping point (mm).
 ※ 2. Minimum pressure to operate the clamp without load.
 ※ 3. It shows the weight of single clamp without link lever.

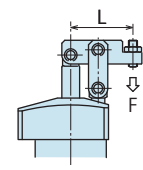

- High-Power Series
- Pneumatic Series
- Hydraulic Series
- Valve / Coupler Hydraulic Unit
- Manual Operation Accessories
- Cautions / Others
- Hole Clamp
 - SFA
 - SFC
- Swing Clamp
 - LHA
 - LHC
 - LHS
 - LHW
 - LG/LT
 - TLA-2
 - TLB-2
 - TLA-1
- Link Clamp
 - LKA
 - LKC
 - LKW
 - LJ/LM
 - TMA-2**
 - TMA-1
- Work Support
 - LD
 - LC
 - TNC
 - TC
- Air Sensing Lift Cylinder
 - LLW
- Linear Cylinder / Compact Cylinder
 - LL
 - LLR
 - LLU
 - DP
 - DR
 - DS
 - DT
- Block Cylinder
 - DBA/DBC
- Centering Vise
 - FVA
 - FVD
 - FVC
- Control Valve
 - BZL
 - BZT
 - BZX/JZG
 - BZS
- Pallet Clamp
 - VS/VT
- Expansion Locating Pin
 - VFL/VFM
 - VFJ/VFK
- Pull Stud Clamp
 - FP
 - FQ
- Customized Spring Cylinder
 - DWA/DWB

Clamping Force Curve

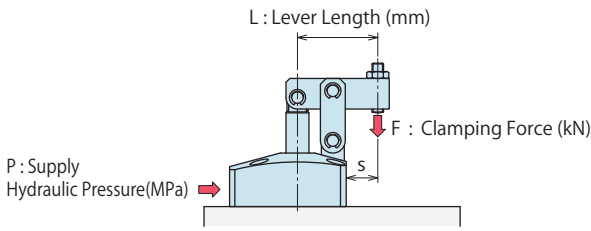

Applicable Model

Double-Acting Model
TMA 0 - 2
BC LCR
1 Body Size

(Ex.) In case of TMA1000-2 :

When supply hydraulic pressure P is 30MPa and lever length L is 56.5mm, clamping force becomes about 7.9kN.

TMA0250-2		Clamping Force Calculation Formula ^{※1} (kN) $F = (1.50 \times P) / (L - 16)$									
Hydraulic Pressure (MPa)	Cylinder Force (kN)	Clamping Force (kN)								Non-Usable Range (mm)	Min. Lever Length (L) (mm)
		Lever Length L (mm)									
		L=25	L=30	L=36.5	L=40	L=50	L=60	L=80	L=100		
35.0	3.6			2.6	2.2	1.5	1.2	0.8	0.6	36.5	
32.5	3.4			2.4	2.0	1.4	1.1	0.8	0.6	33.5	
30.0	3.1			2.2	1.9	1.3	1.0	0.7	0.5	31	
27.5	2.9		2.9	2.0	1.7	1.2	0.9	0.6	0.5	28.5	
25.0	2.6		2.7	1.8	1.6	1.1	0.9	0.6	0.4	26.5	
22.5	2.3	3.8	2.4	1.6	1.4	1.0	0.8	0.5	0.4	25	
20.0	2.1	3.3	2.1	1.5	1.3	0.9	0.7	0.5	0.4	23.5	
17.5	1.8	2.9	1.9	1.3	1.1	0.8	0.6	0.4	0.3	23.5	
15.0	1.6	2.5	1.6	1.1	0.9	0.7	0.5	0.4	0.3	23.5	
12.5	1.3	2.1	1.3	0.9	0.8	0.6	0.4	0.3	0.2	23.5	
10.0	1.0	1.7	1.1	0.7	0.6	0.4	0.3	0.2	0.2	23.5	
7.5	0.8	1.3	0.8	0.5	0.5	0.3	0.3	0.2	0.1	23.5	
5.0	0.5	0.8	0.5	0.4	0.3	0.2	0.2	0.1	0.1	23.5	
3.5	0.4	0.6	0.4	0.3	0.2	0.2	0.1	0.1	0.1	23.5	
Max. Operating Pressure (MPa)		22.8	29.3	35.0	35.0	35.0	35.0	35.0	35.0		

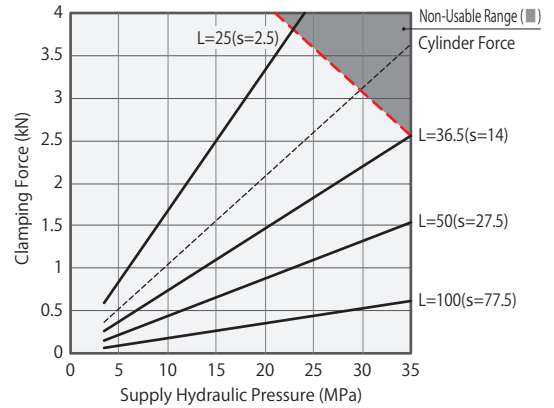

TMA0400-2		Clamping Force Calculation Formula ^{※1} (kN) $F = (2.56 \times P) / (L - 18.5)$									
Hydraulic Pressure (MPa)	Cylinder Force (kN)	Clamping Force (kN)								Non-Usable Range (mm)	Min. Lever Length (L) (mm)
		Lever Length L (mm)									
		L=30	L=35	L=42	L=50	L=60	L=80	L=100	L=120		
35.0	5.4			3.8	2.8	2.2	1.5	1.1	0.9	42	
32.5	5.0			3.5	2.6	2.0	1.4	1.0	0.8	38.5	
30.0	4.6			3.3	2.4	1.9	1.2	0.9	0.8	35.5	
27.5	4.2		4.3	3.0	2.2	1.7	1.1	0.9	0.7	33	
25.0	3.8		3.9	2.7	2.0	1.5	1.0	0.8	0.6	30.5	
22.5	3.5	5.0	3.5	2.5	1.8	1.4	0.9	0.7	0.6	29	
20.0	3.1	4.5	3.1	2.2	1.6	1.2	0.8	0.6	0.5	27	
17.5	2.7	3.9	2.7	1.9	1.4	1.1	0.7	0.5	0.4	25.5	
15.0	2.3	3.3	2.3	1.6	1.2	0.9	0.6	0.5	0.4	25.5	
12.5	1.9	2.8	1.9	1.4	1.0	0.8	0.5	0.4	0.3	25.5	
10.0	1.5	2.2	1.6	1.1	0.8	0.6	0.4	0.3	0.3	25.5	
7.5	1.2	1.7	1.2	0.8	0.6	0.5	0.3	0.2	0.2	25.5	
5.0	0.8	1.1	0.8	0.5	0.4	0.3	0.2	0.2	0.1	25.5	
3.5	0.5	0.8	0.5	0.4	0.3	0.2	0.1	0.1	0.1	25.5	
Max. Operating Pressure (MPa)		24.4	29.7	35.0	35.0	35.0	35.0	35.0	35.0		

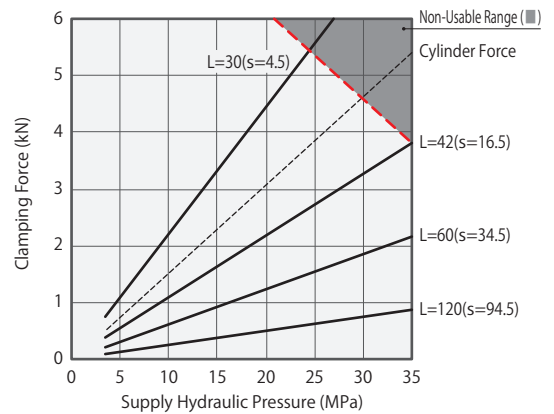

TMA0600-2		Clamping Force Calculation Formula ^{※1} (kN) $F = (4.81 \times P) / (L - 21)$									
Hydraulic Pressure (MPa)	Cylinder Force (kN)	Clamping Force (kN)								Non-Usable Range (mm)	Min. Lever Length (L) (mm)
		Lever Length L (mm)									
		L=35	L=40	L=50	L=60	L=70	L=80	L=100	L=120		
35.0	8.9			5.8	4.3	3.4	2.9	2.1	1.7	50	
32.5	8.3			5.4	4.0	3.2	2.6	2.0	1.6	45.5	
30.0	7.6			5.0	3.7	2.9	2.4	1.8	1.5	41.5	
27.5	7.0		7.0	4.6	3.4	2.7	2.2	1.7	1.3	38.5	
25.0	6.4		6.3	4.1	3.1	2.5	2.0	1.5	1.2	35.5	
22.5	5.7	7.7	5.7	3.7	2.8	2.2	1.8	1.4	1.1	33.5	
20.0	5.1	6.9	5.1	3.3	2.5	2.0	1.6	1.2	1.0	31.5	
17.5	4.5	6.0	4.4	2.9	2.2	1.7	1.4	1.1	0.9	30	
15.0	3.8	5.2	3.8	2.5	1.9	1.5	1.2	0.9	0.7	30	
12.5	3.2	4.3	3.2	2.1	1.5	1.2	1.0	0.8	0.6	30	
10.0	2.5	3.4	2.5	1.7	1.2	1.0	0.8	0.6	0.5	30	
7.5	1.9	2.6	1.9	1.2	0.9	0.7	0.6	0.5	0.4	30	
5.0	1.3	1.7	1.3	0.8	0.6	0.5	0.4	0.3	0.2	30	
3.5	0.9	1.2	0.9	0.6	0.4	0.3	0.3	0.2	0.2	30	
Max. Operating Pressure (MPa)		24.5	28.9	35.0	35.0	35.0	35.0	35.0	35.0		

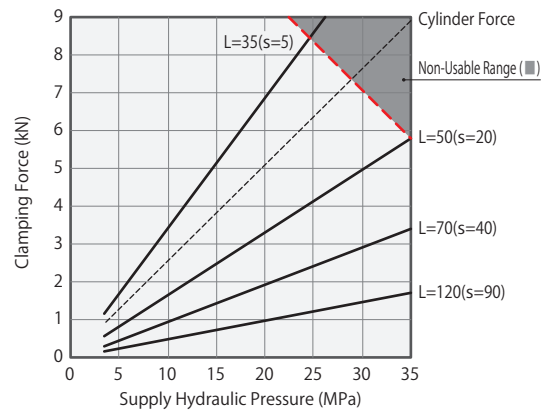

TMA1000-2		Clamping Force Calculation Formula ^{※1} (kN) $F = (8.38 \times P) / (L - 24.5)$									
Hydraulic Pressure (MPa)	Cylinder Force (kN)	Clamping Force (kN)						Non-Usable Range (mm)	Min. Lever Length (L) (mm)		
		Lever Length L (mm)									
		L=40	L=50	L=56.5	L=80	L=100	L=120	L=140	L=160		
35.0	13.3			9.2	5.3	3.9	3.1	2.5	2.2	56.5	
32.5	12.4			8.5	4.9	3.6	2.9	2.4	2.0	51.5	
30.0	11.4			9.9	7.9	4.5	3.3	2.6	2.2	47.5	
27.5	10.5			9.0	7.2	4.2	3.1	2.4	2.0	44	
25.0	9.5		8.2	6.5	3.8	2.8	2.2	1.8	1.5	41	
22.5	8.6	12.2	7.4	5.9	3.4	2.5	2.0	1.6	1.4	38.5	
20.0	7.6	10.8	6.6	5.2	3.0	2.2	1.8	1.5	1.2	36.5	
17.5	6.7	9.5	5.8	4.6	2.6	1.9	1.5	1.3	1.1	36.5	
15.0	5.7	8.1	4.9	3.9	2.3	1.7	1.3	1.1	0.9	36.5	
12.5	4.8	6.8	4.1	3.3	1.9	1.4	1.1	0.9	0.8	36.5	
10.0	3.8	5.4	3.3	2.6	1.5	1.1	0.9	0.7	0.6	36.5	
7.5	2.9	4.1	2.5	2.0	1.1	0.8	0.7	0.5	0.5	36.5	
5.0	1.9	2.7	1.6	1.3	0.8	0.6	0.4	0.4	0.3	36.5	
3.5	1.3	1.9	1.2	0.9	0.5	0.4	0.3	0.3	0.2	36.5	
Max. Operating Pressure (MPa)		24.4	31.7	35.0	35.0	35.0	35.0	35.0	35.0		

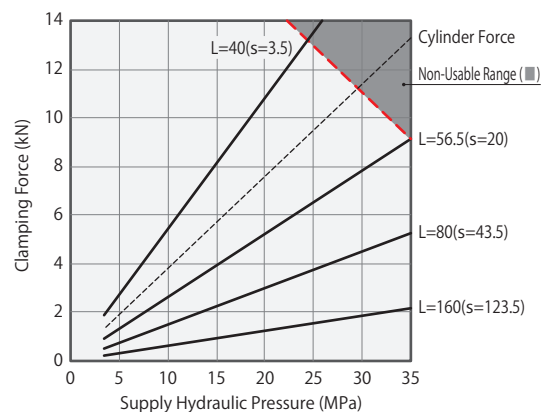

Notes :

1. Tables and graphs show the relationship between the clamping force (kN) and supply hydraulic pressure (MPa).
 2. Cylinder force (when L=0) cannot be calculated from the calculation formula of clamping force.
 3. Clamping force in the non-usable range may cause damage and fluid leakage.
- ※1. F : Clamping Force (kN), P : Supply Hydraulic Pressure (MPa), L : Lever Length (mm).

TMA1600-2		Clamping Force Calculation Formula ※1 (kN) $F = (16.63 \times P) / (L - 30)$										
Hydraulic Pressure (MPa)	Cylinder Force (kN)	Clamping Force (kN) Non-Usable Range (■)										Min. Lever Length (L) (mm)
		L=50	L=60	L=67.5	L=80	L=100	L=120	L=140	L=160			
35.0	21.6			15.5	11.6	8.3	6.5	5.3	4.5	67.5		
32.5	20.0			14.4	10.8	7.7	6.0	4.9	4.2	62		
30.0	18.5		16.6	13.3	10.0	7.1	5.5	4.5	3.8	57		
27.5	16.9		15.2	12.2	9.1	6.5	5.1	4.2	3.5	53		
25.0	15.4	20.8	13.9	11.1	8.3	5.9	4.6	3.8	3.2	49.5		
22.5	13.9	18.7	12.5	10.0	7.5	5.3	4.2	3.4	2.9	46.5		
20.0	12.3	16.6	11.1	8.9	6.7	4.8	3.7	3.0	2.6	43.5		
17.5	10.8	14.6	9.7	7.8	5.8	4.2	3.2	2.6	2.2	42.5		
15.0	9.2	12.5	8.3	6.7	5.0	3.6	2.8	2.3	1.9	42.5		
12.5	7.7	10.4	6.9	5.5	4.2	3.0	2.3	1.9	1.6	42.5		
10.0	6.2	8.3	5.5	4.4	3.3	2.4	1.8	1.5	1.3	42.5		
7.5	4.6	6.2	4.2	3.3	2.5	1.8	1.4	1.1	1.0	42.5		
5.0	3.1	4.2	2.8	2.2	1.7	1.2	0.9	0.8	0.6	42.5		
3.5	2.2	2.9	1.9	1.6	1.2	0.8	0.6	0.5	0.4	42.5		
Max. Operating Pressure (MPa)	25.6	31.6	35.0	35.0	35.0	35.0	35.0	35.0				

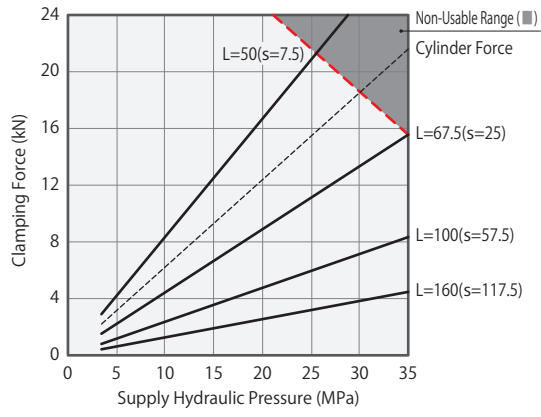

TMA2500-2		Clamping Force Calculation Formula ※1 (kN) $F = (26.06 \times P) / (L - 36)$										
Hydraulic Pressure (MPa)	Cylinder Force (kN)	Clamping Force (kN) Non-Usable Range (■)										Min. Lever Length (L) (mm)
		L=60	L=70	L=77.5	L=100	L=120	L=140	L=160	L=200			
35.0	28.1			22.0	14.3	10.9	8.8	7.4	5.6	77.5		
32.5	26.1			20.4	13.2	10.1	8.1	6.8	5.2	71.5		
30.0	24.1		23.0	18.8	12.2	9.3	7.5	6.3	4.8	66.5		
27.5	22.1		21.1	17.3	11.2	8.5	6.9	5.8	4.4	62		
25.0	20.1	27.1	19.2	15.7	10.2	7.8	6.3	5.3	4.0	58		
22.5	18.1	24.4	17.2	14.1	9.2	7.0	5.6	4.7	3.6	54.5		
20.0	16.1	21.7	15.3	12.6	8.1	6.2	5.0	4.2	3.2	51.5		
17.5	14.1	19.0	13.4	11.0	7.1	5.4	4.4	3.7	2.8	50		
15.0	12.1	16.3	11.5	9.4	6.1	4.7	3.8	3.2	2.4	50		
12.5	10.1	13.6	9.6	7.8	5.1	3.9	3.1	2.6	2.0	50		
10.0	8.0	10.9	7.7	6.3	4.1	3.1	2.5	2.1	1.6	50		
7.5	6.0	8.1	5.7	4.7	3.1	2.3	1.9	1.6	1.2	50		
5.0	4.0	5.4	3.8	3.1	2.0	1.6	1.3	1.1	0.8	50		
3.5	2.8	3.8	2.7	2.2	1.4	1.1	0.9	0.7	0.6	50		
Max. Operating Pressure (MPa)	26.5	31.9	35.0	35.0	35.0	35.0	35.0	35.0				

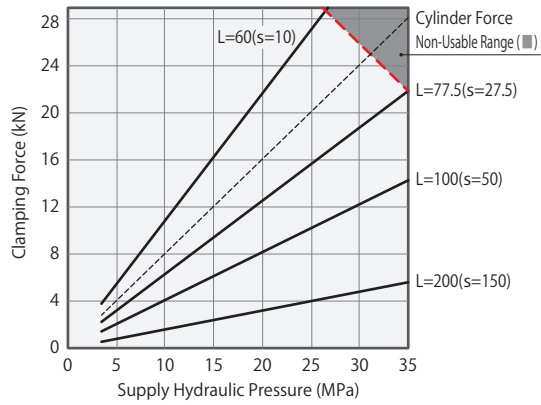

TMA3200-2		Clamping Force Calculation Formula ※1 (kN) $F = (44.91 \times P) / (L - 44)$										
Hydraulic Pressure (MPa)	Cylinder Force (kN)	Clamping Force (kN) Non-Usable Range (■)										Min. Lever Length (L) (mm)
		L=70	L=80	L=95	L=100	L=130	L=160	L=200	L=230			
35.0	39.7			30.8	28.1	18.3	13.6	10.1	8.5	95		
32.5	36.9			28.6	26.1	17.0	12.6	9.4	7.8	87.5		
30.0	34.0			26.4	24.1	15.7	11.6	8.6	7.2	81		
27.5	31.2		34.3	24.2	22.1	14.4	10.6	7.9	6.6	75.5		
25.0	28.4		31.2	22.0	20.0	13.1	9.7	7.2	6.0	71		
22.5	25.5	38.9	28.1	19.8	18.0	11.7	8.7	6.5	5.4	67		
20.0	22.7	34.5	25.0	17.6	16.0	10.4	7.7	5.8	4.8	63		
17.5	19.8	30.2	21.8	15.4	14.0	9.1	6.8	5.0	4.2	60		
15.0	17.0	25.9	18.7	13.2	12.0	7.8	5.8	4.3	3.6	60		
12.5	14.2	21.6	15.6	11.0	10.0	6.5	4.8	3.6	3.0	60		
10.0	11.3	17.3	12.5	8.8	8.0	5.2	3.9	2.9	2.4	60		
7.5	8.5	13.0	9.4	6.6	6.0	3.9	2.9	2.2	1.8	60		
5.0	5.7	8.6	6.2	4.4	4.0	2.6	1.9	1.4	1.2	60		
3.5	4.0	6.0	4.4	3.1	2.8	1.8	1.4	1.0	0.8	60		
Max. Operating Pressure (MPa)	24.6	29.6	35.0	35.0	35.0	35.0	35.0	35.0				

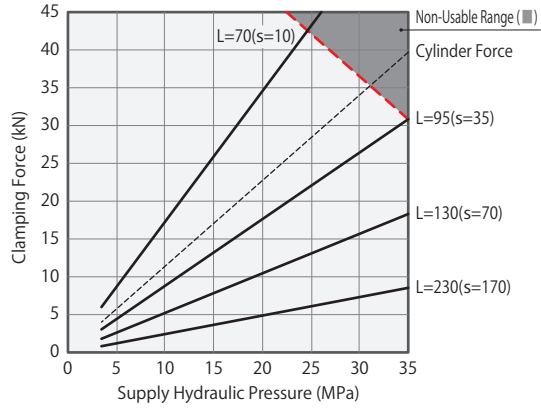

- High-Power Series
- Pneumatic Series
- Hydraulic Series**
- Valve / Coupler Hydraulic Unit
- Manual Operation Accessories
- Cautions / Others
- Hole Clamp
 - SFA
 - SFC
- Swing Clamp
 - LHA
 - LHC
 - LHS
 - LHW
 - LG/LT
 - TLA-2
 - TLB-2
 - TLA-1
- Link Clamp**
 - LKA
 - LKC
 - LKW
 - LJ/LM
 - TMA-2**
 - TMA-1
- Work Support
 - LD
 - LC
 - TNC
 - TC
- Air Sensing Lift Cylinder
 - LLW
- Linear Cylinder / Compact Cylinder
 - LL
 - LLR
 - LLU
 - DP
 - DR
 - DS
 - DT
- Block Cylinder
 - DBA/DBC
- Centering Vise
 - FVA
 - FVD
 - FVC
- Control Valve
 - BZL
 - BZT
 - BZX/JZG
 - BZS
- Pallet Clamp
 - VS/VT
- Expansion Locating Pin
 - VFL/VFM
 - VFJ/VFK
- Pull Stud Clamp
 - FP
 - FQ
- Customized Spring Cylinder
 - DWA/DWB

Allowable Offset Graph

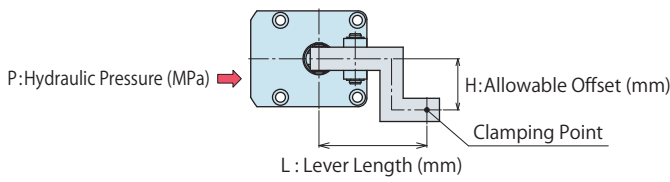

Applicable Model

Double-Acting Model

TMA 0 - 2 B C L C R

1 Body Size

(Ex.) In case of TMA1600 :

When supply hydraulic pressure P is 30MPa and lever length L is 140mm, allowable offset becomes about 20mm.

TMA0250-2

Hydraulic Pressure (MPa)	Allowable Offset H (mm) Non-Usable Range (■)							
	Lever Length L (mm)							
	L=25	L=30	L=36.5	L=40	L=50	L=60	L=80	L=100
35	■	■	2	2	3	3	4	5
32.5	■	■	2	3	3	4	5	7
30	■	■	5	5	7	8	11	13
27.5	■	6	7	8	10	12	16	20
25	■	8	10	11	13	16	21	27
22.5	8	10	12	13	17	20	27	33
20	10	12	15	16	20	24	32	40
17.5	12	14	17	19	23	28	37	46
15	13	16	19	21	27	32	42	53
12.5	15	18	22	24	30	36	48	60
10	17	20	24	27	33	40	53	66

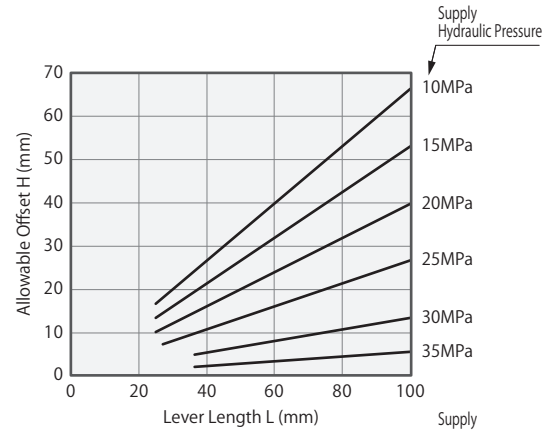

TMA0400-2

Hydraulic Pressure (MPa)	Allowable Offset H (mm) Non-Usable Range (■)							
	Lever Length L (mm)							
	L=30	L=35	L=42	L=50	L=60	L=80	L=100	L=120
35	■	■	2	2	3	4	5	5
32.5	■	■	2	3	3	5	6	7
30	■	■	5	6	7	9	11	14
27.5	■	6	7	9	10	14	17	21
25	■	8	10	11	14	18	23	28
22.5	9	10	12	14	17	23	29	34
20	10	12	14	17	21	28	34	41
17.5	12	14	17	20	24	32	40	48
15	14	16	19	23	28	37	46	55
12.5	15	18	22	26	31	41	52	62
10	17	20	24	29	34	46	57	69

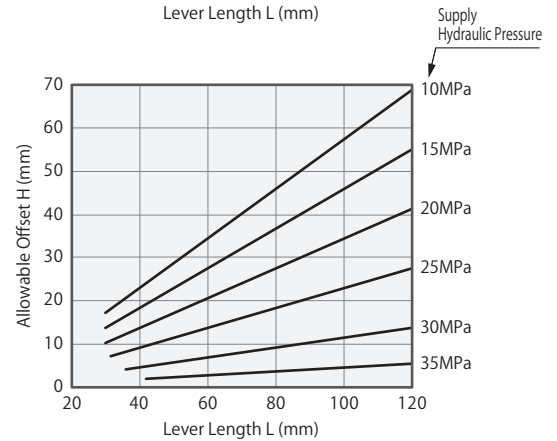

TMA0600-2

Hydraulic Pressure (MPa)	Allowable Offset H (mm) Non-Usable Range (■)							
	Lever Length L (mm)							
	L=35	L=40	L=50	L=60	L=70	L=80	L=100	L=120
35	■	■	3	4	4	5	6	7
32.5	■	■	3	4	5	5	7	8
30	■	■	7	8	9	11	13	16
27.5	■	8	10	12	14	16	20	24
25	9	11	13	16	19	22	27	32
22.5	12	13	17	20	24	27	34	40
20	14	16	20	24	28	32	40	48
17.5	16	19	24	28	33	38	47	57
15	19	22	27	32	38	43	54	65
12.5	21	24	30	36	42	48	61	73
10	24	27	34	40	47	54	67	81

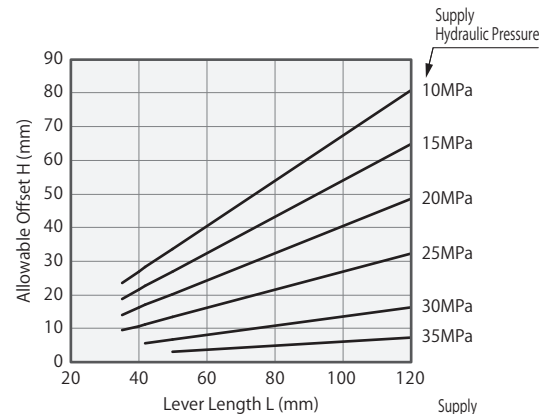

TMA1000-2

Hydraulic Pressure (MPa)	Allowable Offset H (mm) Non-Usable Range (■)							
	Lever Length L (mm)							
	L=40	L=50	L=56.5	L=80	L=100	L=120	L=140	L=160
35	■	■	3	4	5	6	7	9
32.5	■	■	4	6	7	9	10	12
30	■	■	7	8	12	15	18	23
27.5	■	11	12	18	22	26	31	35
25	■	15	17	24	29	35	41	47
22.5	15	18	21	29	37	44	51	59
20	18	22	25	35	44	53	62	71
17.5	21	26	29	41	51	62	72	82
15	24	29	33	47	59	71	82	94
12.5	26	33	37	53	66	79	93	106
10	29	37	42	59	73	88	103	118

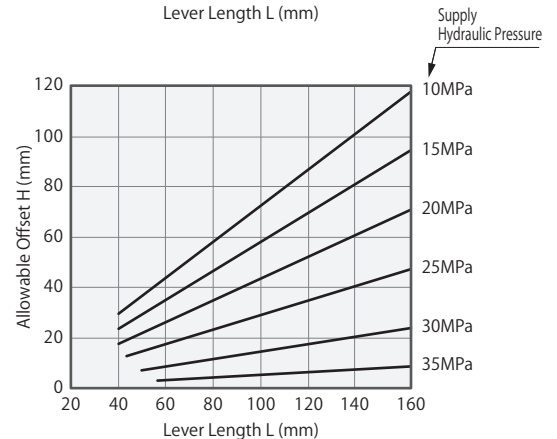

Notes :

1. Tables and graphs show the relationship between the lever length and the allowable offset according to the supply hydraulic pressure.
2. Using the lever beyond allowable offset may cause deformation, seizure and fluid leakage etc.
3. The tables and graphs are only for reference. The design should be carried out with allowance fully taken into consideration.

TMA1600-2

Hydraulic Pressure (MPa)	Allowable Offset H (mm) Non-Usable Range (■)							
	Lever Length L (mm)							
	L=50	L=60	L=67.5	L=80	L=100	L=120	L=140	L=160
35	■	■	4	5	6	7	9	10
32.5	■	■	4	5	7	8	9	11
30	■	8	9	11	13	16	19	21
27.5	■	12	13	16	20	24	28	32
25	■	16	18	21	27	32	37	43
22.5	17	20	22	27	33	40	47	53
20	20	24	27	32	40	48	56	64
17.5	23	28	31	37	47	56	65	74
15	27	32	36	43	53	64	74	85
12.5	30	36	40	48	60	72	84	96
10	33	40	45	53	66	80	93	106

TMA2500-2

Hydraulic Pressure (MPa)	Allowable Offset H (mm) Non-Usable Range (■)							
	Lever Length L (mm)							
	L=60	L=70	L=77.5	L=100	L=120	L=140	L=160	L=200
35	■	■	4	6	7	8	9	11
32.5	■	■	5	7	8	9	11	13
30	■	9	10	13	16	19	21	26
27.5	■	14	15	20	24	28	32	40
25	■	18	20	26	32	37	42	53
22.5	20	23	26	33	40	46	53	66
20	24	28	31	40	48	56	63	79
17.5	28	32	36	46	56	65	74	93
15	32	37	41	53	63	74	85	106
12.5	36	42	46	59	71	83	95	119
10	40	46	51	66	79	93	106	132

TMA3200-2

Hydraulic Pressure (MPa)	Allowable Offset H (mm) Non-Usable Range (■)							
	Lever Length L (mm)							
	L=70	L=80	L=95	L=100	L=130	L=160	L=200	L=230
35	■	■	6	6	8	10	13	14
32.5	■	■	7	7	9	11	14	16
30	■	■	13	14	18	22	28	32
27.5	■	17	20	21	27	34	42	48
25	■	22	27	28	36	45	56	65
22.5	25	28	33	35	46	56	70	81
20	29	34	40	42	55	67	84	97
17.5	34	39	47	49	64	79	98	113
15	39	45	53	56	73	90	112	129
12.5	44	50	60	63	82	101	126	145
10	49	56	67	70	91	112	140	161

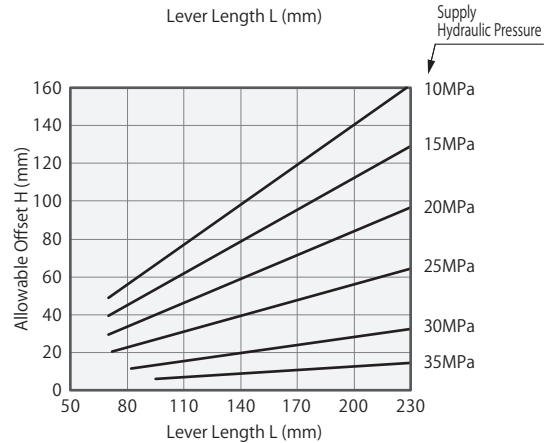
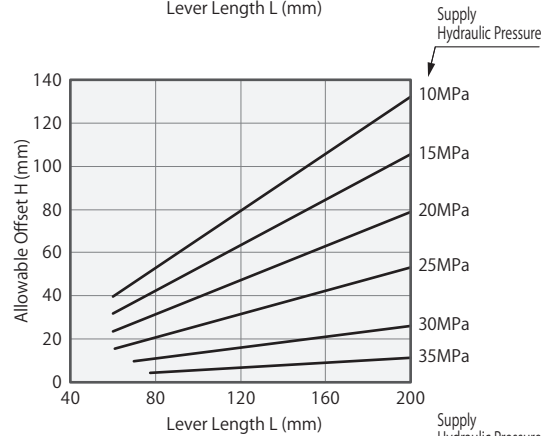
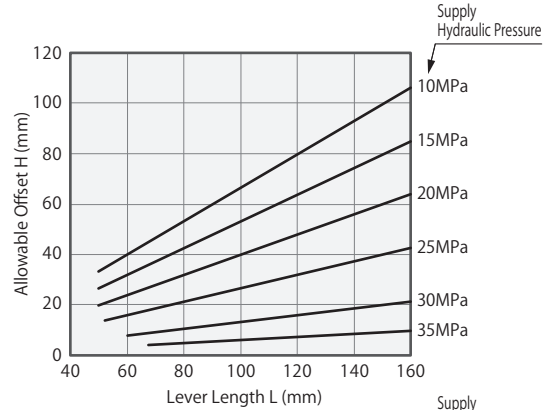

- High-Power Series
- Pneumatic Series
- Hydraulic Series**
- Valve / Coupler Hydraulic Unit
- Manual Operation Accessories
- Cautions / Others

- Hole Clamp
 - SFA
 - SFC
- Swing Clamp
 - LHA
 - LHC
 - LHS
 - LHW
 - LG/LT
 - TLA-2
 - TLB-2
 - TLA-1
- Link Clamp**
 - LKA
 - LKC
 - LKW
 - LJ/LM
 - TMA-2**
 - TMA-1
- Work Support
 - LD
 - LC
 - TNC
 - TC
- Air Sensing Lift Cylinder
 - LLW
- Linear Cylinder / Compact Cylinder
 - LL
 - LLR
 - LLU
 - DP
 - DR
 - DS
 - DT
- Block Cylinder
 - DBA/DBC
- Centering Vise
 - FVA
 - FVD
 - FVC
- Control Valve
 - BZL
 - BZT
 - BZX/JZG
 - BZS
- Pallet Clamp
 - VS/VT
- Expansion Locating Pin
 - VFL/VFM
 - VFJ/VFK
- Pull Stud Clamp
 - FP
 - FQ
- Customized Spring Cylinder
 - DWA/DWB

External Dimensions

C : Gasket Option (With G Thread Plug)
 ※The drawing shows the locked state of TMA-2CC.

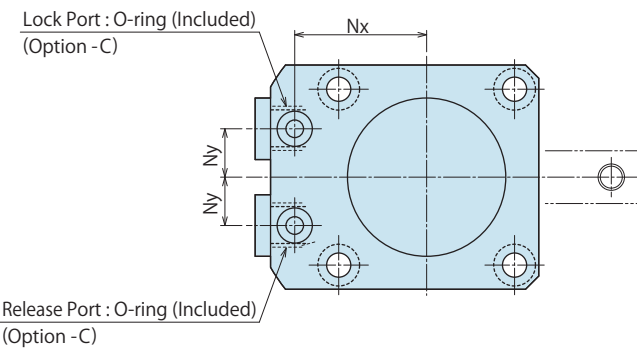
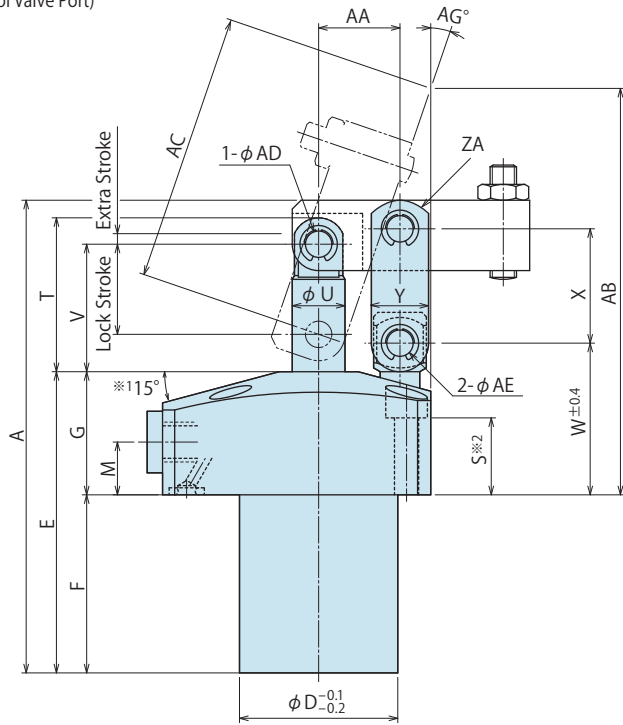
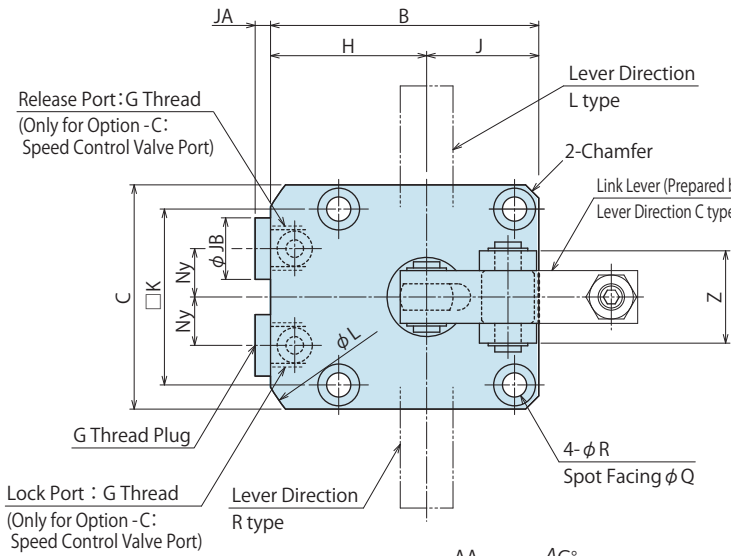

Notes :

- ※1. Flange inclination angle is 12° only for TMA1000.
- ※2. Mounting bolts are not provided. Please prepare them according to the mounting height referring to dimension 'S'.
 1. Please use the provided pin (equivalent to φADf6, φAEf6, HRC60) as mounting pin for lever.
 2. Please prepare speed control valve (Refer to P.947) if necessary.

Machining Dimensions of Mounting Area

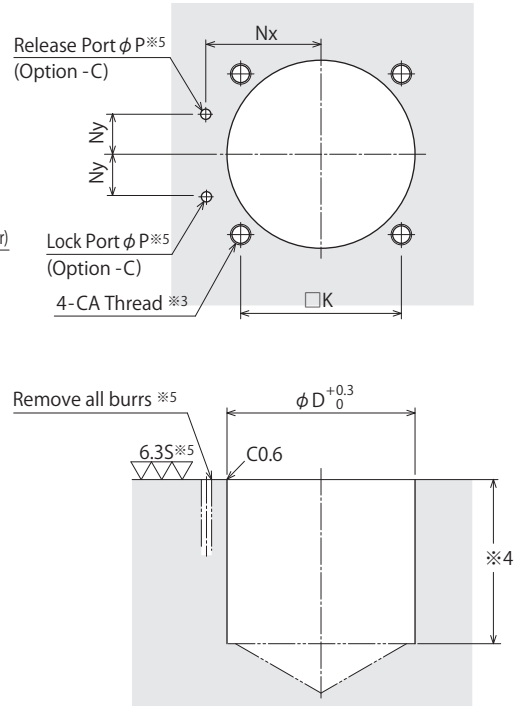

Notes :

- ※3. CA tapping depth of the mounting bolt should be decided according to the mounting height referring to dimension 'S'.
- ※4. The depth of the body mounting hole φD should be decided according to the mounting height referring to dimension 'F'.
- ※5. The machining dimension is for -C : Gasket option.

Piping Method

B : Piping Option (G Thread)
 ※The drawing shows the locked state of TMA-2BC.

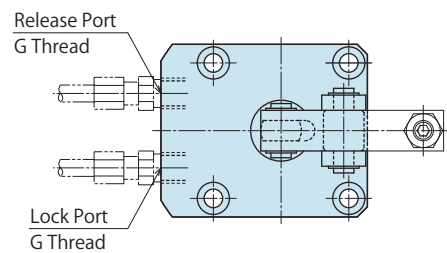

External Dimensions and Machining Dimensions for Mounting

(mm)

Model No.	TMA0250-2□□	TMA0400-2□□	TMA0600-2□□	TMA1000-2□□	TMA1600-2□□	TMA2500-2□□	TMA3200-2□□
Full Stroke	20.5	23.5	26	29.5	35	41	49
Lock Stroke	17.5	20.5	23	26.5	32	38	46
Extra Stroke	3	3	3	3	3	3	3
A	87	97.5	108.5	122.5	151	175.5	205
B	54	61	69	82.5	94.5	109.5	127
C	45	51	60	73	85	100	120
D	33	36	43	48	60	70	85
E	53.5	58.5	63	68.5	84	96.5	111
F	27.5	30.5	33	35.5	46	54.5	61
G	26	28	30	33	38	42	50
H	31.5	35.5	39	46	52	59.5	67
J	22.5	25.5	30	36.5	42.5	50	60
K	34	40	47	57	65	75	88
L	73	81	88	103	116	136	147
M	11	12	13	14	16	17	19
Nx	26	30	33.5	40	45	52.5	60
Ny	9	10	12	15	16	18.5	20
P	3	3	3	3	5	5	5
Q	9	9	11	14	17.5	20	20
R	5.5	5.5	6.8	9	11	14	14
S	15.5	16.5	16	17.5	17.5	18	24
T	30.5	35	37.5	45	55	64.5	77
U	10	12	14	18	22	28	32
V	25	29	31.5	37	45	52	62
W	31.5	34.5	37.5	42	49	54.5	64
X	22	26	30	35.5	43.5	52.5	64
Y	13	13	16	19	25	28	32
Z	21	21	28	37	40	49	64
ZA	R7.5	R7.5	R10	R12	R15	R16	R18
Chamfer	3	3	3	4	5	8	(φ147)
AA	16	18.5	21	24.5	30	36	44
AB	78.7	92.4	103.9	118.4	131.8	148.5	173.6
AC	50.2	61.2	71.7	83	90.8	104.6	122.5
AD	6	6	6	8	10	12	15
AE	6	6	8	10	12	15	18
AG	20.2	18.9	19.9	20.5	21.5	22.4	23.1
CA (Nominal × Pitch)	M5×0.8	M5×0.8	M6×1	M8×1.25	M10×1.5	M12×1.75	M12×1.75
JA	3	3	3	3	3.5	3.5	3.5
JB	14	14	14	14	19	19	19
G Thread	G1/8	G1/8	G1/8	G1/8	G1/4	G1/4	G1/4
O-ring (Option -C)	1BP5	1BP5	1BP5	1BP5	1BP7	1BP7	1BP7

- High-Power Series
- Pneumatic Series
- Hydraulic Series
- Valve / Coupler Hydraulic Unit
- Manual Operation Accessories
- Cautions / Others
- Hole Clamp
 - SFA
 - SFC
- Swing Clamp
 - LHA
 - LHC
 - LHS
 - LHW
 - LG/LT
 - TLA-2
 - TLB-2
 - TLA-1
- Link Clamp
 - LKA
 - LKC
 - LKW
 - LJ/LM
 - TMA-2**
 - TMA-1
- Work Support
 - LD
 - LC
 - TNC
 - TC
- Air Sensing Lift Cylinder
 - LLW
- Linear Cylinder / Compact Cylinder
 - LL
 - LLR
 - LLU
 - DP
 - DR
 - DS
 - DT
- Block Cylinder
 - DBA/DBC
- Centering Vise
 - FVA
 - FVD
 - FVC
- Control Valve
 - BZL
 - BZT
 - BZX/JZG
 - BZS
- Pallet Clamp
 - VS/VT
- Expansion Locating Pin
 - VFL/VFM
 - VFJ/VFK
- Pull Stud Clamp
 - FP
 - FQ
- Customized Spring Cylinder
 - DWA/DWB

Link Lever Design Dimension

※ Reference for designing link lever.

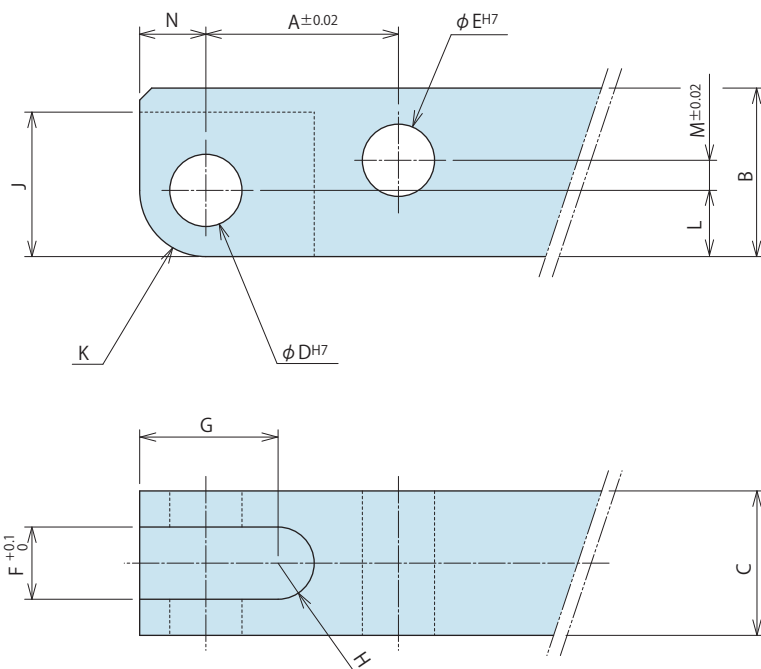

Calculation List of Link Lever Design Dimension

Corresponding Model No.	TMA0250	TMA0400	TMA0600	TMA1000	TMA1600	TMA2500	TMA3200
A	16	18.5	21	24.5	30	36	44
B	14	16	20	25	32	38	45
C	12 ⁰ _{-0.3}	12 ⁰ _{-0.3}	16 ⁰ _{-0.3}	19 ⁰ _{-0.3}	22 ⁰ _{-0.3}	25 ⁰ _{-0.3}	32 ⁰ _{-0.4}
D	6 ^{+0.012} ₀	6 ^{+0.012} ₀	6 ^{+0.012} ₀	8 ^{+0.015} ₀	10 ^{+0.015} ₀	12 ^{+0.018} ₀	15 ^{+0.018} ₀
E	6 ^{+0.012} ₀	6 ^{+0.012} ₀	8 ^{+0.015} ₀	10 ^{+0.015} ₀	12 ^{+0.018} ₀	15 ^{+0.018} ₀	18 ^{+0.018} ₀
F	6	6	8	10	11	13	16
G	11.5	13	12.5	16	20	24	28
H	R3	R3	R4	R5	R5.5	R6.5	R8
J	12	13	13	17.5	22	26	30.5
K	R5.5	R6	R6	R8	R10	R11	R13
L	5.5	6	6	8	10	11	13
M	2.5	3.5	6	7.5	9.5	13	16
N	5.5	6	6	8	10	11	13

Notes :

1. Please design the link lever length according to the performance curve.
2. If the link lever is not in accordance with the dimension shown above, performance may be degraded and damage can occur.
3. Please use the attached pin (equivalent to φADf6, φAEf6, HRC60) as the mounting pin for lever.
(Please refer to each external dimension of TMA for the dimensions φAD and φAE.)

Accessories : Link Lever (LZ-LJ3)

Model No. Indication

LZ 048 0 - LJ3

 Size
(Refer to the table)

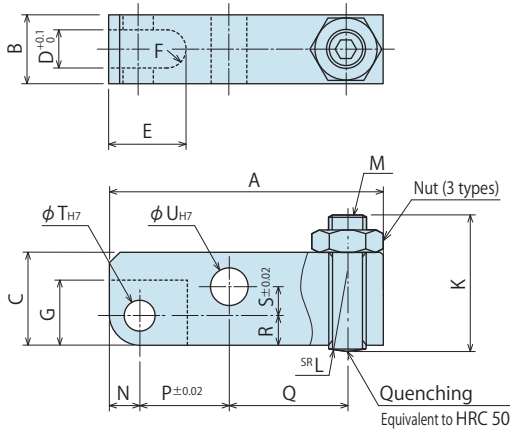
 Design No.
(Revision Number)

Model No.	LZ0400-LJ3	LZ0480-LJ3	LZ0550-LJ3	LZ0650-LJ3	LZ0750-LJ3	LZ0900-LJ3	LZ1050-LJ3
Corresponding Model No.	TMA0250	TMA0400	TMA0600	TMA1000	TMA1600	TMA2500	TMA3200
A	48	54	64	74.5	88.5	102.5	125
B	12 ^{-0.3} ₀	12 ^{-0.3} ₀	16 ^{-0.3} ₀	19 ^{-0.3} ₀	22 ^{-0.3} ₀	25 ^{-0.3} ₀	32 ^{-0.4} ₀
C	14	16	20	25	32	38	45
D	6	6	8	10	11	13	16
E	14.5	16	16.5	21	25.5	30.5	36
F	R3	R3	R4	R5	R5.5	R6.5	R8
G	12	13	13	17.5	22	26	30.5
K	23	26	32	39	47	56	65
L	10	10	15	20	30	45	60
M	M6×1	M6×1	M8×1.25	M10×1.5	M12×1.75	M16×2	M20×2.5
N	5.5	6	6	8	10	11	13
P	16	18.5	21	24.5	30	36	44
Q	20.5	23.5	29	32	37.5	41.5	51
R	5.5	6	6	8	10	11	13
S	2.5	3.5	6	7.5	9.5	13	16
T	6 ^{+0.012} ₀	6 ^{+0.012} ₀	6 ^{+0.012} ₀	8 ^{+0.015} ₀	10 ^{+0.015} ₀	12 ^{+0.018} ₀	15 ^{+0.018} ₀
U	6 ^{+0.012} ₀	6 ^{+0.012} ₀	8 ^{+0.015} ₀	10 ^{+0.015} ₀	12 ^{+0.018} ₀	15 ^{+0.018} ₀	18 ^{+0.018} ₀

- Notes : 1. Material S45C Surface Finishing: Alkaline Blackening
 2. Please use the attached pin (equivalent to φ ADf6, φ Aef6, HRC60) as the mounting pin for lever.

Accessories : Material Link Lever (LZ-LJ2)

Model No. Indication

LZ 048 0 - LJ2

 Size
(Refer to the table)

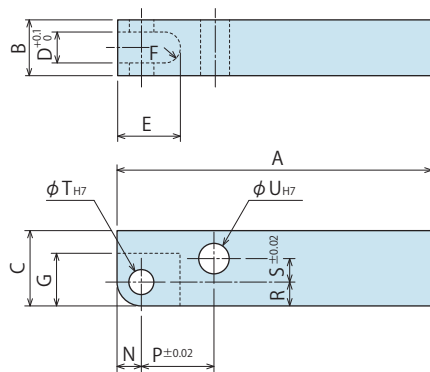
 Design No.
(Revision Number)

Model No.	LZ0400-LJ2	LZ0480-LJ2	LZ0550-LJ2	LZ0650-LJ2	LZ0750-LJ2	LZ0900-LJ2	LZ1050-LJ2
Corresponding Model No.	TMA0250	TMA0400	TMA0600	TMA1000	TMA1600	TMA2500	TMA3200
A	75	85	90	105	110	160	220
B	12 ^{-0.3} ₀	12 ^{-0.3} ₀	16 ^{-0.3} ₀	19 ^{-0.3} ₀	22 ^{-0.3} ₀	25 ^{-0.3} ₀	32 ^{-0.4} ₀
C	14	16	20	25	32	38	45
D	6	6	8	10	11	13	16
E	14.5	16	16.5	21	25.5	30.5	36
F	R3	R3	R4	R5	R5.5	R6.5	R8
G	12	13	13	17.5	22	26	30.5
N	5.5	6	6	8	10	11	13
P	16	18.5	21	24.5	30	36	44
R	5.5	6	6	8	10	11	13
S	2.5	3.5	6	7.5	9.5	13	16
T	6 ^{+0.012} ₀	6 ^{+0.012} ₀	6 ^{+0.012} ₀	8 ^{+0.015} ₀	10 ^{+0.015} ₀	12 ^{+0.018} ₀	15 ^{+0.018} ₀
U	6 ^{+0.012} ₀	6 ^{+0.012} ₀	8 ^{+0.015} ₀	10 ^{+0.015} ₀	12 ^{+0.018} ₀	15 ^{+0.018} ₀	18 ^{+0.018} ₀

- Notes : 1. Material S45C Surface Finishing: Alkaline Blackening
 2. If necessary, the front end should be additionally machined.
 3. Please use the attached pin (equivalent to φ ADf6, φ Aef6, HRC60) as the mounting pin for lever.

High-Power
Series

Pneumatic Series

Hydraulic Series

Valve / Coupler
Hydraulic UnitManual Operation
Accessories

Cautions / Others

Hole Clamp

SFA
SFC

Swing Clamp

LHA
LHC
LHS
LHW
LG/LT
TLA-2
TLB-2
TLA-1

Link Clamp

LKA
LKC
LKW
LJ/LM
TMA-2
TMA-1

Work Support

LD
LC
TNC
TCAir Sensing
Lift Cylinder

LLW

Linear Cylinder /
Compact CylinderLL
LLR
LLU
DP
DR
DS
DT

Block Cylinder

DBA/DBC

Centering Vise

FVA
FVD
FVC

Control Valve

BZL
BZT
BZX/JZG
BZS

Pallet Clamp

VS/VT

Expansion
Locating PinVFL/VFM
VFJ/VFK

Pull Stud Clamp

FP
FQCustomized
Spring Cylinder

DWA/DWB

Cautions

● Notes for Design

- 1) Check Specifications
 - Please use each product according to the specifications.
- 2) Notes for Circuit Design
 - Please read "Notes on Hydraulic Cylinder Speed Control Unit" for proper hydraulic circuit design. Improper circuit design may lead to malfunctions and damages. (Refer to P.1356)
 - Ensure there is no possibility of supplying hydraulic pressure to the lock port and the release port simultaneously.
- 3) Notes for Link Lever Design
 - Make sure no force is applied to the piston rod except from the axial direction. The usage like the one shown in the drawing below will apply a large bending stress to the piston rod and must be avoided.

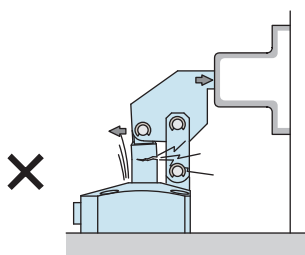

- If offset load is applied on the link part, use it within the allowable range of "Allowable Offset Graph".
- 4) Protect the exposed area of the piston rod when using on a welding fixture.
 - If spatter attaches to the sliding surface it could lead to malfunction and fluid leakage.
 - 5) When clamping on a sloped surface of the workpiece
 - Make sure the clamping surface and the mounting surface of the clamp are parallel.

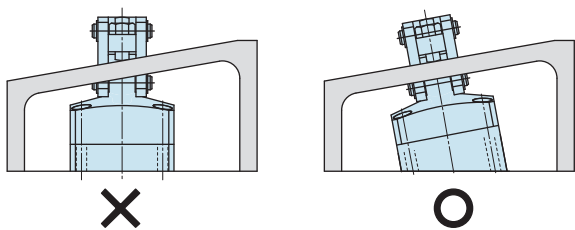

- 6) When using in a dry environment
 - The link pin can be dried out. Grease it periodically or use a special pin. Contact us for the specifications of special pins.
- 7) Notes for LKA-M/N, LKW
 - When using air sensing link clamp (LKA-M/N, LKW), make sure to check the Notes for Design · Installation · Use (Pages shown below).
 - Link clamp with air sensing option LKA-M/N : Refer to P.633.
 - Link clamp with air sensing valve LKW : Refer to P.655.

● Installation Notes

- 1) Check the Usable Fluid
 - Please use the appropriate fluid by referring to the Hydraulic Fluid List (P.1355).
- 2) Installation of the Product
 - When mounting the clamp, use hexagonal socket bolts as multiple bolt holes for mounting (with tensile strength of 12.9) and tighten them with the torque shown in the table below. Tightening with greater torque than recommended can dent the seating surface or break the bolt.

	Model No.	Thread Size	Tightening Torque (N·m)
LKA LKC LKW	LKA0360	M4×0.7	4.0
	LKA0400	M5×0.8	8.0
	LKC0400/LKW0401		
	LKA0480	M5×0.8	8.0
	LKC0480/LKW0481		
	LKA0550	M6×1	14
	LKC0550/LKW0551		
	LKA0650	M6×1	14
	LKC0650/LKW0651		
	LKA0750/LKW0751	M8×1.25	33
LKA0900	M10×1.5	65	
LKA1050	M12×1.75	114	
LJ/LM	LJ0302/LM0300	M4×0.7	3.2
	LJ0362/LM0360	M4×0.7	3.2
	LJ0402/LM0400	M5×0.8	6.3
	LJ0482/LM0480	M5×0.8	6.3
	LJ0552/LM0550	M6×1	10
	LJ0652/LM0650	M6×1	10
	LJ0752/LM0750	M8×1.25	25
	LJ0902	M10×1.5	58.8
LJ1052	M12×1.75	98	
TMA	TMA0250	M5×0.8	6.9
	TMA0400	M5×0.8	6.9
	TMA0600	M6×1	11.8
	TMA1000	M8×1.25	25
	TMA1600	M10×1.5	58.8
	TMA2500	M12×1.75	98
TMA3200	M12×1.75	98	

3) Installation / Removal of the Link Lever

- When inserting the link pin, do not hit the pin directly with a hammer. When using a hammer to insert the pin, always use a cover plate with a smaller diameter than the spring ring groove on the pin.

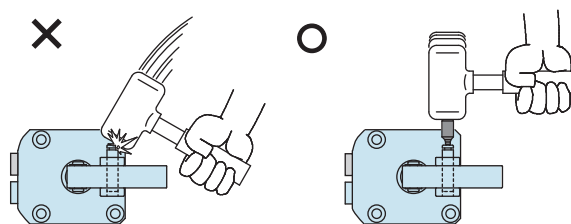

- The following shows the tightening torque for the mounting bolt of the quick change lever option A.

Quick Change Lever Option A

Model No.	Thread Size	Tightening Torque (N·m)
LKA0360-□□-A LJ0362-□□-A / LM0360-□□-A	M3×0.5	1.3
LKA0400-□□-A LKC0400-□□-A / LKW0401-□□-A LJ0402-□□-A / LM0400-□□-A	M3×0.5	1.3
LKA0480-□□-A LKC0480-□□-A / LKW0481-□□-A LJ0482-□□-A / LM0480-□□-A	M3×0.5	1.3
LKA0550-□□-A LKC0550-□□-A / LKW0551-□□-A LJ0552-□□-A / LM0550-□□-A	M3×0.5	1.3
LKA0650-□□-A LKC0650-□□-A / LKW0651-□□-A LJ0652-□□-A / LM0650-□□-A	M4×0.7	3.2
LKA0750-□□-A / LKW0751-□□-A LJ0752-□□-A / LM0750-□□-A	M4×0.7	3.2
LKA0900-□□-A	M5×0.8	6.3
LKA1050-□□-A	M5×0.8	6.3

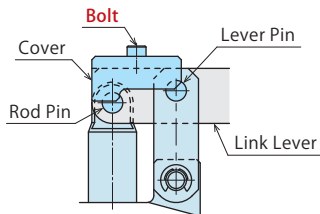

4) Notes on dual rod option (-D) for dog application.

- When attaching dog, set up the piston so that it will not turn around. Please secure the dog or cam and prevent any rotation or torque on the piston rod. Tightening torque of mounting screw is shown in the table below.

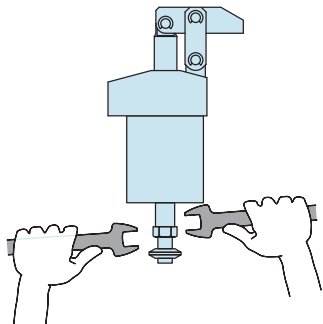

Model No.	Thread Size	Tightening Torque (N·m)
LKA0360-□□D	M4×0.7	3.2
LKA0400-□□D	M6×1	10
LKA0480-□□D	M8×1.25	25
LKA0550-□□D	M8×1.25	25
LKA0650-□□D	M8×1.25	25
LKA0750-□□D	M10×1.5	50
LKA0900-□□D	M10×1.5	50
LKA1050-□□D	M10×1.5	50

5) Speed Adjustment

- Adjust the speed so that the total operating time is one second or more. If the clamp operates too fast the parts will be worn out leading to premature damage and ultimately complete equipment failure.
- Please make sure to release air from the circuit before adjusting speed. It will be difficult to adjust the speed accurately with air mixed in the circuit.
- Turn the speed control valve gradually from the low-speed side (small flow) to the high-speed side (large flow) to adjust the speed.

- High-Power Series
- Pneumatic Series
- Hydraulic Series**
- Valve / Coupler Hydraulic Unit
- Manual Operation Accessories
- Cautions / Others

- Hole Clamp
 - SFA
 - SFC

- Swing Clamp
 - LHA
 - LHC
 - LHS
 - LHW
 - LG/LT
 - TLA-2
 - TLB-2
 - TLA-1

- Link Clamp**
 - LKA
 - LKC
 - LKW
 - LJ/LM
 - TMA-2
 - TMA-1

- Work Support
 - LD
 - LC
 - TNC
 - TC

- Air Sensing Lift Cylinder
 - LLW

- Linear Cylinder / Compact Cylinder
 - LL
 - LLR
 - LLU
 - DP
 - DR
 - DS
 - DT

- Block Cylinder
 - DBA/DBC

- Centering Vise
 - FVA
 - FVD
 - FVC

- Control Valve
 - BZL
 - BZT
 - BZX/JZG
 - BZS

- Pallet Clamp
 - VS/VT

- Expansion Locating Pin
 - VFL/VFM
 - VFJ/VFK

- Pull Stud Clamp
 - FP
 - FQ

- Customized Spring Cylinder
 - DWA/DWB

※ Please refer to P.1355 for common cautions. • Installation Notes • Hydraulic Fluid List • Notes on Hydraulic Cylinder Speed Control Circuit • Notes on Handling • Maintenance/Inspection • Warranty

● Cautions

● Installation Notes (For Hydraulic Series)

- 1) Check the Usable Fluid
 - Please use the appropriate fluid by referring to the Hydraulic Fluid List.
- 2) Procedure before Piping
 - The pipeline, piping connector and fixture circuits should be cleaned by thorough flushing.
 - The dust and cutting chips in the circuit may lead to fluid leakage and malfunction.
 - There is no filter provided with Kosmek's product except for a part of valves which prevents foreign materials and contaminants from getting into the circuit.
- 3) Applying Sealing Tape
 - Wrap with tape 1 to 2 times following the screw direction.
 - Pieces of the sealing tape can lead to oil leakage and malfunction.
 - Please implement piping construction in a clear environment to prevent anything getting in products.
- 4) Air Bleeding of the Hydraulic Circuit
 - If the hydraulic circuit has excessive air, the action time may become very long. If air enters the circuit after connecting the hydraulic port or under the condition of no air in the oil tank, please perform the following steps.
 - ① Reduce hydraulic pressure to less than 2MPa.
 - ② Loosen the cap nut of pipe fitting closest to the clamp by one full turn.
 - ③ Shake the pipeline to loosen the outlet of pipe fitting.
Hydraulic fluid mixed with air comes out.

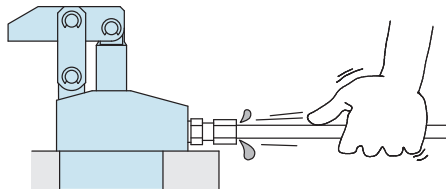

- ④ Tighten the cap nut after bleeding.
- ⑤ It is more effective to release air at the highest point inside the circuit or at the end of the circuit.
(Set an air bleeding valve at the highest point inside the circuit.)

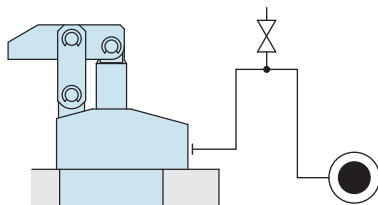

5) Checking Looseness and Retightening

- At the beginning of the machine installation, the bolt and nut may be tightened lightly. Check the looseness and re-tighten as required.

● Hydraulic Fluid List

Maker	ISO Viscosity Grade ISO-VG-32	
	Anti-Wear Hydraulic Oil	Multi-Purpose Hydraulic Oil
Showa Shell Sekiyu	Tellus S2 M 32	Morlina S2 B 32
Idemitsu Kosan	Daphne Hydraulic Fluid 32	Daphne Super Multi Oil 32
JX Nippon Oil & Energy	Super Hyrando 32	Super Mulpus DX 32
Cosmo Oil	Cosmo Hydro AW32	Cosmo New Mighty Super 32
ExxonMobil	Mobil DTE 24	Mobil DTE 24 Light
Matsumura Oil	Hydol AW-32	
Castrol	Hyspin AWS 32	

Note : Please contact manufacturers when customers require products in the list above.

● Notes on Hydraulic Cylinder Speed Control Unit



Please pay attention to the cautions below. Design the hydraulic circuit for controlling the action speed of hydraulic cylinder. Improper circuit design may lead to malfunctions and damages. Please review the circuit design in advance.

● Flow Control Circuit for Single Acting Cylinder

For spring return single acting cylinders, restricting flow during release can extremely slow down or disrupt release action. The preferred method is to control the flow during the lock action using a valve that has free-flow in the release direction. It is also preferred to provide a flow control valve at each actuator.

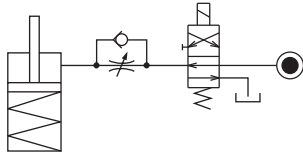

Accelerated clamping speed by excessive hydraulic flow to the cylinder may sustain damage. In this case add flow control to regulate flow. (Please add flow control to release flow if the lever weight is put on at the time of release action when using swing clamps.)

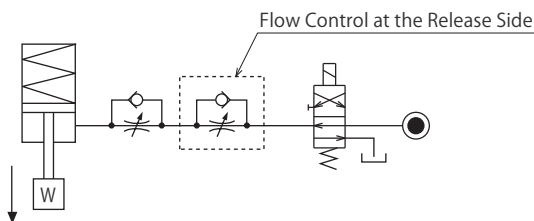

● Flow Control Circuit for Double Acting Cylinder

Flow control circuit for double acting cylinder should have meter-out circuits for both the lock and release sides. Meter-in control can have adverse effect by presence of air in the system.

However, in the case of controlling LKE, TMA, TLA, both lock side and release side should be meter-in circuit.

Refer to P.75 for speed adjustment of LKE.

For TMA and TLA, if meter-out circuit is used, abnormal high pressure is created, which causes oil leakage and damage.

【Meter-out Circuit】 (Except LKE/TMA/TLA)

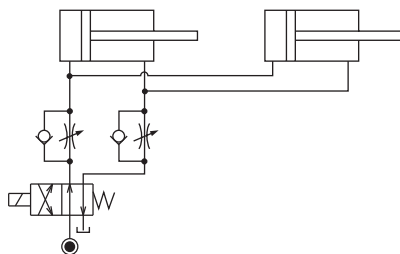

【Meter-in Circuit】 (LKE/TMA/TLA must be controlled with meter-in.)

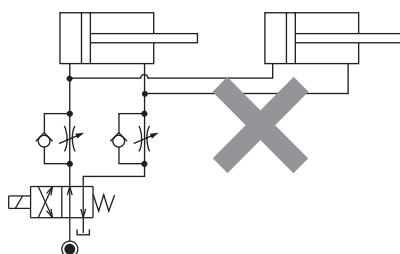

In the case of meter-out circuit, the hydraulic circuit should be designed with the following points.

- ① Single acting components should not be used in the same flow control circuit as the double acting components. The release action of the single acting cylinders may become erratic or very slow.

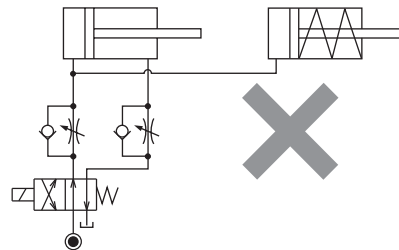

Refer to the following circuit when both the single acting cylinder and double acting cylinder are used together.

- Separate the control circuit.

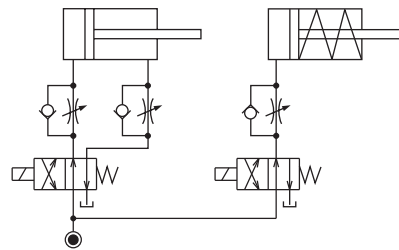

- Reduce the influence of double acting cylinder control unit. However, due to the back pressure in tank line, single action cylinder is activated after double action cylinder works.

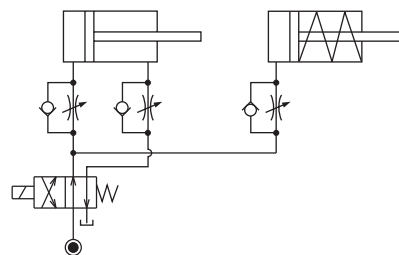

- ② In the case of meter-out circuit, the inner circuit pressure may increase during the cylinder action because of the fluid supply. The increase of the inner circuit pressure can be prevented by reducing the supplied fluid beforehand via the flow control valve. Especially when using sequence valve or pressure switches for clamping detection. If the back pressure is more than the set pressure then the system will not work as it is designed to.

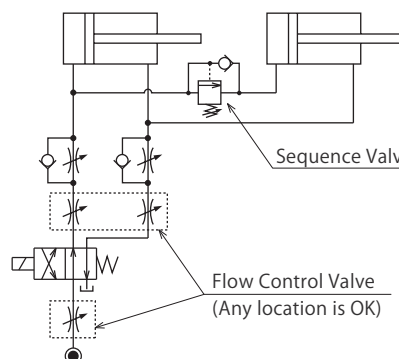

- High-Power Series
- Pneumatic Series
- Hydraulic Series
- Valve / Coupler Hydraulic Unit
- Manual Operation Accessories
- Cautions / Others

Cautions

- Installation Notes (For Hydraulic Series)
- Hydraulic Fluid List
- Notes on Hydraulic Cylinder Speed Control Circuit
- Notes on Handling
- Maintenance/Inspection
- Warranty

Company Profile

- Company Profile
- Our Products
- History

Index

- Search by
- Alphabetical Order

Sales Offices

ⓘ Cautions

● Notes on Handling

- 1) It should be operated by qualified personnel.
 - The hydraulic machine and air compressor should be operated and maintained by qualified personnel.
- 2) Do not operate or remove the product unless the safety protocols are ensured.
 - ① The machine and equipment can only be inspected or prepared when it is confirmed that the safety devices are in place.
 - ② Before the product is removed, make sure that the above-mentioned safety devices are in place. Shut off the pressure and power source, and make sure no pressure exists in the air and hydraulic circuits.
 - ③ After stopping the product, do not remove until the temperature drops.
 - ④ Make sure there is no abnormality in the bolts and respective parts before restarting the machine or equipment.
- 3) Do not touch a clamp (cylinder) while it is working. Otherwise, your hands may be injured due to clinching.

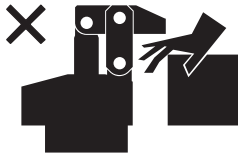

- 4) Do not disassemble or modify.
 - If the equipment is taken apart or modified, the warranty will be voided even within the warranty period.

● Maintenance and Inspection

- 1) Removal of the Machine and Shut-off of Pressure Source
 - Before the machine is removed, make sure that safety devices and preventive devices are in place. Shut off the pressure and power source, and make sure no pressure exists in the air and hydraulic circuits.
 - Make sure there is no abnormality in the bolts and respective parts before restarting.
- 2) Regularly clean the area around the piston rod and plunger.
 - If it is used when the surface is contaminated with dirt, it may lead to packing seal damage, malfunctioning and fluid leakage.

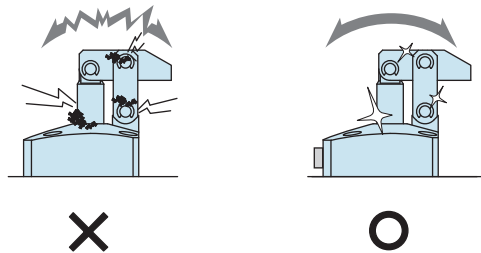

- 3) Please clean out the reference surfaces on a regular basis (taper reference surface and seating surface) of the locating products. (VS/VT/VFL/VFM/VFJ/VFK/WVS/VWM/VWK/VX/VXE/VXF)
 - The locating products, except VX/VXE/VXF model, can remove contaminants with cleaning functions. However, hardened cutting chips, adhesive coolant and others may not be removed. Make sure there are no contaminants before installing a workpiece/pallet.
 - Continuous use with contaminant on components will lead to locating accuracy failure, malfunction and fluid leakage.

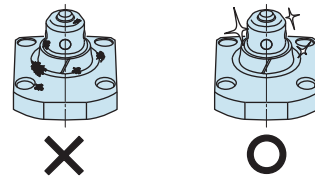

- 4) If disconnecting by couplers, air bleeding should be carried out on a regular basis to avoid air mixed in the circuit.
- 5) Regularly tighten nut, bolt, pin, cylinder, pipe line and others to ensure proper use.
- 6) Make sure the hydraulic fluid has not deteriorated.
- 7) Make sure there is a smooth action without an irregular noise.
 - Especially when it is restarted after left unused for a long period, make sure it can be operated correctly.
- 8) The products should be stored in the cool and dark place without direct sunshine or moisture.
- 9) Please contact us for overhaul and repair.

● Warranty

1) Warranty Period

- The product warranty period is 18 months from shipment from our factory or 12 months from initial use, whichever is earlier.

2) Warranty Scope

- If the product is damaged or malfunctions during the warranty period due to faulty design, materials or workmanship, we will replace or repair the defective part at our expense. Defects or failures caused by the following are not covered.

- ① If the stipulated maintenance and inspection are not carried out.
- ② If the product is used while it is not suitable for use based on the operator's judgment, resulting in defect.
- ③ If it is used or operated in an inappropriate way by the operator. (Including damage caused by the misconduct of the third party.)
- ④ If the defect is caused by reasons other than our responsibility.
- ⑤ If repair or modifications are carried out by anyone other than Kosmek, or without our approval and confirmation, it will void warranty.
- ⑥ Other caused by natural disasters or calamities not attributable to our company.
- ⑦ Parts or replacement expenses due to parts consumption and deterioration. (Such as rubber, plastic, seal material and some electric components.)

Damages excluding from direct result of a product defect shall be excluded from the warranty.

High-Power
Series

Pneumatic Series

Hydraulic Series

Valve / Coupler
Hydraulic Unit

Manual Operation
Accessories

Cautions / Others

Cautions

Installation Notes
(For Hydraulic Series)

Hydraulic Fluid List

Notes on Hydraulic Cylinder
Speed Control Circuit

Notes on Handling

Maintenance/
Inspection

Warranty

Company Profile

Company Profile

Our Products

History

Index

Search by
Alphabetical Order

Sales Offices



WAHLTEC GmbH
 T: +49 (7584) 9238883
 F: +49 (7584) 9238887
 kosmek@wahltec.de
 www.wahltec.de

Control Valve

Model **BZL**

Model **BZT**

Model **BZX**

Model **JZG**

Model **BZS**



Directly-Attached Speed Control Valve, Air Bleed Valve, G-Thread Plug and Sequence Valve

- **Directly Attached to Clamps**

Control Valves :

Speed control valve, air bleed valve, G-thread plug and sequence valve attached directly into Kosmek hydraulic clamp G-thread piping option.

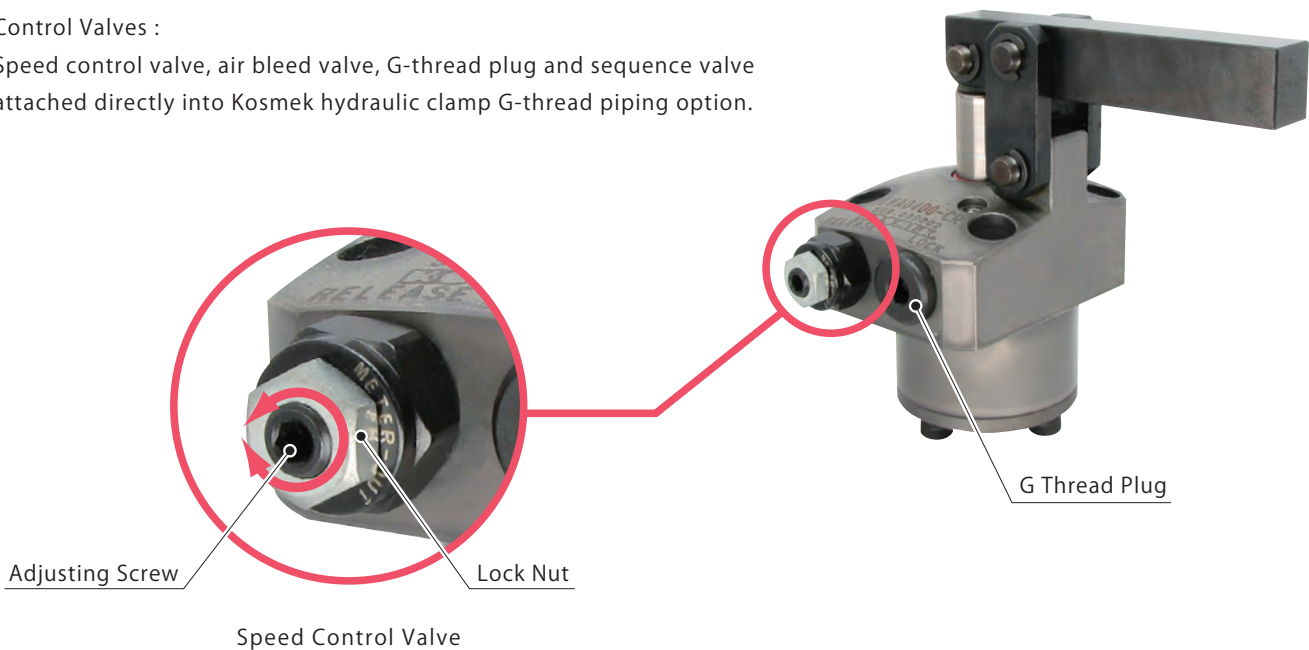

Speed Control Valve

Model **BZL**
Model **BZT**



Air Bleed Valve

Model **BZX**









G Thread Plug

Model **JZG**

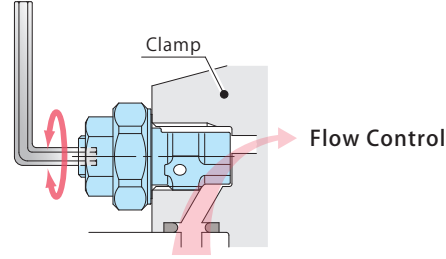
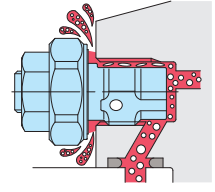

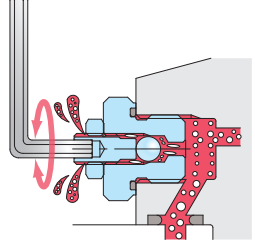
Direct-Mount Sequence Valve

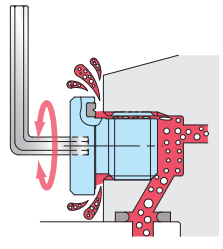
Model **BZS**

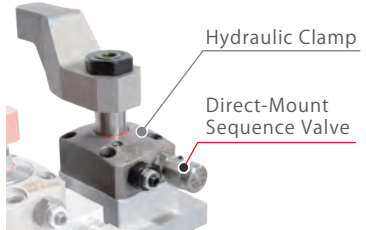
	Operating Pressure Range	Action Description
<p>Speed Control Valve (For Low Pressure)</p> <p>Model BZL → P.949</p> 	7MPa or less	<p>Adjust the flow rate with a wrench. Able to adjust the clamping speed individually.</p> 
<p>Speed Control Valve (For High Pressure)</p> <p>Model BZT → P.953</p>	35MPa or less	<p>Air bleeding in the circuit is possible by loosening the speed control valve.</p> 
<p>Air Bleed Valve</p> <p>Model BZX → P.955</p> 	25MPa or less	<p>Air bleeding in the circuit is possible by wrench.</p> 
<p>G Thread Plug</p> <p>Model JZG → P.957</p> 	35MPa or less	<p>Air bleeding in the circuit is possible by loosening the G thread plug.</p> 
<p>Direct-Mount Sequence Valve</p> <p>Model BZS → P.959</p> 	7MPa or less	<p>Sequence Valve directly attaches to KOSMEK hydraulic clamp's G-thread piping option. Controls the operating sequence of each actuator.</p> 

High-Power Series

Pneumatic Series

Hydraulic Series

Valve / Coupler Hydraulic Unit

Manual Operation Accessories

Cautions / Others

Hole Clamp

- SFA
- SFC

Swing Clamp

- LHA
- LHC
- LHS
- LHW
- LG/LT
- TLA-2
- TLB-2
- TLA-1

Link Clamp

- LKA
- LKC
- LKW
- LJ/LM
- TMA-2
- TMA-1

Work Support

- LD
- LC
- TNC
- TC

Air Sensing Lift Cylinder

- LLW

Linear Cylinder / Compact Cylinder

- LL
- LLR
- LLU
- DP
- DR
- DS
- DT

Block Cylinder

- DBA/DBC

Centering Vise

- FVA
- FVD
- FVC

Control Valve

- BZL
- BZT
- BZX/JZG
- BZS

Pallet Clamp

- VS/VT

Expansion Locating Pin

- VFL/VFM
- VFJ/VFK

Pull Stud Clamp

- FP
- FQ

Customized Spring Cylinder

- DWA/DWB

Model No. Indication (Speed Control Valve for High Pressure)

BZT 0 **10** **1** - **A**

1
2
3



1 G Thread Size

10 : Thread Part G1/8A Thread

20 : Thread Part G1/4A Thread

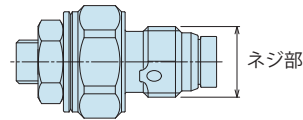

2 Design No.

1 : Revision Number

3 Control Method

A : Meter-in

※ Meter-out option is not available for BZT.

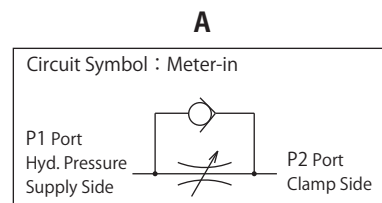

Specifications

Model No.	BZT0101-A	BZT0201-A
Max. Operating Pressure MPa	35	
Min. Operating Pressure MPa	10	
Control Method	Meter-in	
G Thread Size	G1/8A	G1/4A
Cracking Pressure MPa	0.04	
Max. Passage Area mm ²	2.6	5.0
Usable Fluid	General Hydraulic Oil Equivalent to ISO-VG-32	
Operating Temperature °C	0 ~ 70	
Tightening Torque for Main Body N·m	10	25
Weight g	12	26

- Notes :
1. It must be mounted with recommended torque. Because of the structure of the metal seal, if mounting torque is insufficient, the flow control valve may not be able to adjust the flow rate.
 2. Do not attach a used BZT to other clamps.
Flow control will not be made because the bottom depth difference of G thread makes metal seal insufficient.

Applicable Products

Model	TLA-2 (Double Action) Swing Clamp	TLB-2 (Double Action) Swing Clamp	TLA-1 (Single Action) Swing Clamp	TMA-2 (Double Action) Link Clamp	TMA-1 (Single Action) Link Clamp
BZT0101-A	TLA0801-2C□□	TLB0801-2C□□	TLA0802-1C□	TMA0250-2C□	TMA0250-1C□
	TLA1001-2C□□	TLB1001-2C□□	TLA1002-1C□	TMA0400-2C□	TMA0400-1C□
	TLA1601-2C□□	TLB1601-2C□□	TLA1602-1C□	TMA0600-2C□	TMA0600-1C□
				TMA1000-2C□	TMA1000-1C□
BZT0201-A	TLA2001-2C□□	TLB2001-2C□□	TLA2002-1C□	TMA1600-2C□	TMA1600-1C□
	TLA2501-2C□□	TLB2501-2C□□	TLA2502-1C□	TMA2500-2C□	TMA2500-1C□
	TLA4001-2C□□	TLB4001-2C□□	TLA4002-1C□	TMA3200-2C□	TMA3200-1C□

- Notes :
1. It is not recommended to use BZT for TL□040□ / TL□060□ since they have small cylinder capacity and it is difficult to adjust the speed.
 2. In case of controlling TMA, TLA, both lock side and release side should be meter-in circuit.
If meter-out circuit is used, abnormal high pressure is created, which causes oil leakage and damage.

External Dimensions

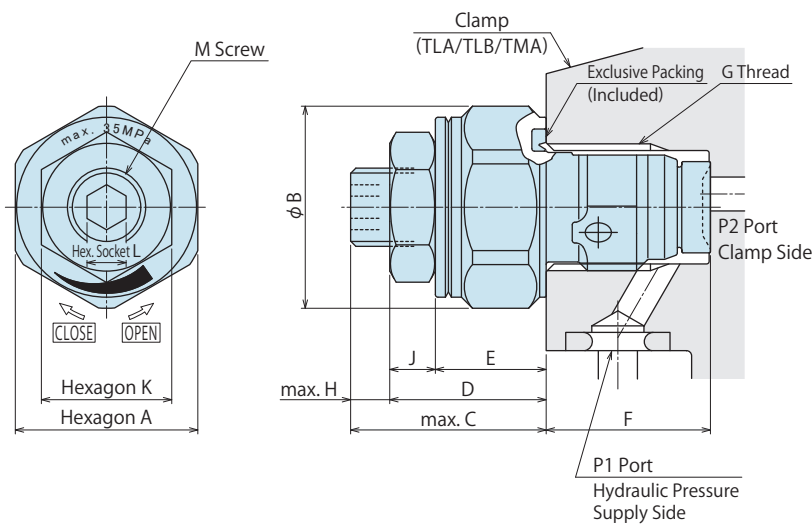

Machining Dimensions of Mounting Area

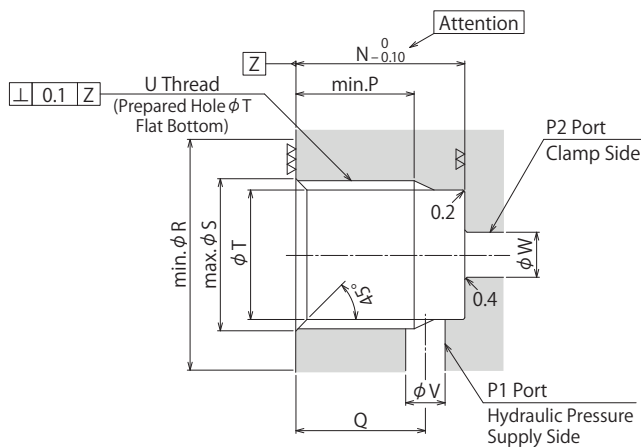

Model No.	BZT0101-A	BZT0201-A
A	14	18
B	15.5	20
C	15	16
D	12	13
E	8.5	9.5
F	(12.6)	(16.1)
G	G1/8	G1/4
H	3	3
J	3.5	3.5
K	10	10
L	3	3
M (Nominal×Pitch)	M6×0.75	M6×0.75
N	12.5	16
P	8.5	11
Q	9.5	12
R	16	20.5
S	10	13.5
T	8.7	11.5
U	G1/8	G1/4
V	2.5 ~ 3.5	3.5 ~ 4.5
W	2.5 ~ 5	3.5 ~ 7

Notes :

1. Since the $\nabla\nabla\nabla$ area is sealing part, be careful not to damage it.
2. Since the $\nabla\nabla$ area is the metal sealing part of BZL, be careful not to damage it. (Especially when deburring)
3. No cutting chips or burr should be at the tolerance part of machining hole.
4. As shown in the drawing, P1 port is used as the hydraulic supply side and P2 port as the clamp side.

Notes

1. Please read "Notes on Hydraulic Cylinder Speed Control Unit" for proper hydraulic circuit design.
Improper circuit design may lead to malfunctions and damages. (Refer to P.1356)
2. It is dangerous to release the air under high pressure. It must be done under lower pressure.
(For reference : the minimum operating range of the product within the circuit.)
3. When the cylinder capacity is small, the speed of flow may not be controlled properly. (Recommended Cylinder Capacity : 3cm³ or more)

High-Power
Series

Pneumatic Series

Hydraulic Series

Valve / Coupler
Hydraulic UnitManual Operation
Accessories

Cautions / Others

Hole Clamp

SFA
SFC

Swing Clamp

LHA
LHC
LHS
LHW
LG/LT
TLA-2
TLB-2
TLA-1

Link Clamp

LKA
LKC
LKW
LJ/LM
TMA-2
TMA-1

Work Support

LD
LC
TNC
TC

Air Sensing

Lift Cylinder

LLW

Linear Cylinder /

Compact Cylinder

LL
LLR
LLU
DP
DR
DS
DT

Block Cylinder

DBA/DBC

Centering Vise

FVA
FVD
FVC

Control Valve

BZL
BZT
BZX/JZG
BZS

Pallet Clamp

VS/VT

Expansion

Locating Pin

VFL/VFM
VFJ/VFK

Pull Stud Clamp

FP
FQCustomized
Spring Cylinder

DWA/DWB

● Model No. Indication (G Thread Plug with Air Bleeding Function)

JZG0 1 0

1 2



1 G Thread Size

- 1 : Thread Part G1/8A Thread
- 2 : Thread Part G1/4A Thread
- 3 : Thread Part G3/8A Thread

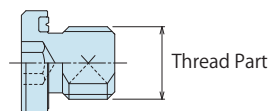

2 Design No.

- 0 : Revision Number

● Specifications

Model No.	JZG010	JZG020	JZG030	
Max. Operating Pressure	MPa 35			
Withstanding Pressure	MPa 42			
G Thread Size	G1/8A	G1/4A	G3/8A	
Usable Fluid	General Hydraulic Oil Equivalent to ISO-VG-32			
Operating Temperature	°C 0 ~ 70			
Tightening Torque for Main Body N·m	Female Thread Side Material : Steel	10	25	35
	Female Thread Side Material : Aluminum (For LT/LM※1)	8	20	28
Weight	g 7	15	23	

- Notes :
1. Air bleeding under high pressure is dangerous. It must be done under lower pressure.
(For reference : the minimum operation pressure range of the product within the circuit)
 2. Refer to the machining dimensions of BZL mounting area when installing JZG into a hydraulic circuit.
- ※1. Body material of LT/LM is aluminum alloy, so install it with the tightening torque for aluminum.

Applicable Products

Model No.	DBA (Double Action) Block Cylinder	DBC (Double Action) Block Cylinder	FVA (Double Action) Centering Vise	FVC (Double Action) Centering Vise	FVD (Double Action) Centering Vise			
JZG010	DBA0250-C□□	DBC0250-C□□	FVA0401	FVC0630	FVD1600			
	DBA0320-C□□	DBC0320-C□□	FVA0631		FVD2500			
JZG020	DBA0400-C□□	DBC0400-C□□		FVC1000	FVD4000			
	DBA0500-C□□	DBC0500-C□□		FVC1600				

Model No.	LC (Single Action) Work Support	LHA (Double Action) Swing Clamp	LHC (Double Action) Swing Clamp	LHE (Double Action) High-Power Swing Clamp	LHS (Double Action) Swing Clamp	LHW (Double Action) Swing Clamp	LT (Single Action) Swing Clamp	LG (Single Action) Swing Clamp
JZG010	LC0262-C□□	LHA0360-C□□□	LHC0360-C□□□	LHE0300-C□□	LHS0360-C□□□	LHW040□-C□□□	LT0301-C□□□	LG0301-C□□□
	LC0302-C□□	LHA0400-C□□□	LHC0400-C□□□	LHE0360-C□□	LHS0400-C□□□	LHW048□-C□□□	LT036□-C□□□	LG036□-C□□□
	LC0362-C□□	LHA0480-C□□□	LHC0480-C□□□	LHE0400-C□□	LHS0480-C□□□	LHW055□-C□□□	LT040□-C□□□	LG040□-C□□□
	LC0402-C□□□	LHA0550-C□□□	LHC0550-C□□□	LHE0480-C□□	LHS0550-C□□□		LT048□-C□□□	LG048□-C□□□
	LC0482-C□□□			LHE0550-C□□			LT055□-C□□□	LG055□-C□□□
	LC0552-C□□□							
LC0652-C□□□								
JZG020	LC0752-C□□□	LHA0650-C□□□	LHC0650-C□□□		LHS0650-C□□□	LHW065□-C□□□	LT065□-C□□□	LG065□-C□□□
	LC0902-C□□□	LHA0750-C□□□			LHS0750-C□□□	LHW0751-C□□□	LT075□-C□□□	LG075□-C□□□
JZG030		LHA0900-C□□□			LHS0900-C□□□			LG090□-C□□□
		LHA1050-C□□□			LHS1050-C□□□			LG105□-C□□□

Model No.	LKA (Double Action) Link Clamp	LKC (Double Action) Link Clamp	LKE (Double Action) High-Power Link Clamp	LKW (Double Action) Link Clamp	LM (Single Action) Link Clamp	LJ (Single Action) Link Clamp	LL (Double Action) Linear Cylinder	LLR (Double Action) Linear Cylinder
JZG010	LKA0360-C□□□	LKC0400-C□□□	LKE0300-C□□	LKW040□-C□□□	LM0300-C□□	LJ0302-C□□	LL0360-C□□□	LLR0360-C□□□
	LKA0400-C□□□	LKC0480-C□□□	LKE0360-C□□	LKW048□-C□□□	LM0360-C□□	LJ0362-C□□	LL0400-C□□□	LLR0400-C□□□
	LKA0480-C□□□	LKC0550-C□□□	LKE0400-C□□	LKW055□-C□□□	LM0400-C□□	LJ0402-C□□	LL0480-C□□□	LLR0480-C□□□
	LKA0550-C□□□		LKE0480-C□□		LM0480-C□□	LJ0482-C□□	LL0550-C□□□	LLR0550-C□□□
		LKE0550-C□□		LM0550-C□□	LJ0552-C□□			
JZG020	LKA0650-C□□□	LKC0650-C□□□		LKW065□-C□□□	LM0650-C□□	LJ0652-C□□	LL0650-C□□□	LLR0650-C□□□
	LKA0750-C□□□			LKW0751-C□□□	LM0750-C□□	LJ0752-C□□	LL0750-C□□□	LLR0750-C□□□
JZG030	LKA0900-C□□□					LJ0902-C□□	LL0900-C□□□	LLR0900-C□□□
	LKA1050-C□□□					LJ1052-C□□	LL1050-C□□□	LLR1050-C□□□

Model No.	LLW (Double Action) Lift Cylinder	TLA-2 (Double Action) Swing Clamp	TLB-2 (Double Action) Swing Clamp	TLA-1 (Single Action) Swing Clamp	TMA-2 (Double Action) Link Clamp	TMA-1 (Double Action) Link Clamp
JZG010	LLW036□-C□□□	TLA0401-2C□□	TLB0401-2C□□	TLA0402-1C□	TMA0250-2C□	TMA0250-1C□
	LLW040□-C□□□	TLA0601-2C□□	TLB0601-2C□□	TLA0602-1C□	TMA0400-2C□	TMA0400-1C□
	LLW048□-C□□□	TLA0801-2C□□	TLB0801-2C□□	TLA0802-1C□	TMA0600-2C□	TMA0600-1C□
		TLA1001-2C□□	TLB1001-2C□□	TLA1002-1C□	TMA1000-2C□	TMA1000-1C□
	TLA1601-2C□□	TLB1601-2C□□	TLA1602-1C□			
JZG020		TLA2001-2C□□	TLB2001-2C□□	TLA2002-1C□	TMA1600-2C□	TMA1600-1C□
		TLA2501-2C□□	TLB2501-2C□□	TLA2502-1C□	TMA2500-2C□	TMA2500-1C□
		TLA4001-2C□□	TLB4001-2C□□	TLA4002-1C□	TMA3200-2C□	TMA3200-1C□

External Dimensions

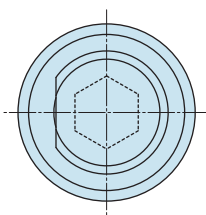
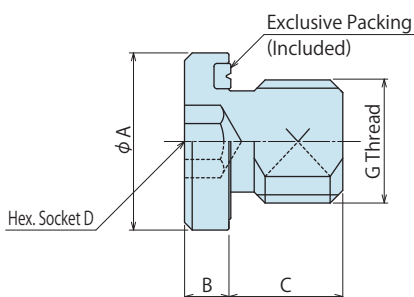

Model No.	JZG010	JZG020	JZG030
A	14	18	22
B	3.5	4.5	4.5
C	8	9	10
D	5	6	8
G	G1/8A	G1/4A	G3/8A

High-Power
Series

Pneumatic Series

Hydraulic Series

Valve / Coupler
Hydraulic UnitManual Operation
Accessories

Cautions / Others

Hole Clamp

SFA

SFC

Swing Clamp

LHA

LHC

LHS

LHW

LG/LT

TLA-2

TLB-2

TLA-1

Link Clamp

LKA

LKC

LKW

LJ/LM

TMA-2

TMA-1

Work Support

LD

LC

TNC

TC

Air Sensing

Lift Cylinder

LLW

Linear Cylinder /

Compact Cylinder

LL

LLR

LLU

DP

DR

DS

DT

Block Cylinder

DBA/DBC

Centering Vise

FVA

FVD

FVC

Control Valve

BZL

BZT

BZX/JZG

BZS

Pallet Clamp

VS/VT

Expansion

Locating Pin

VFL/VFM

VFJ/VFK

Pull Stud Clamp

FP

FQ

Customized

Spring Cylinder

DWA/DWB

Manifold Block

Model WHZ-MD

Model LZY-MD

Model LZ-MS

Model LZ-MP

Model TMZ-1MB

Model TMZ-2MB

Model DZ-MG

Model DZ-MS

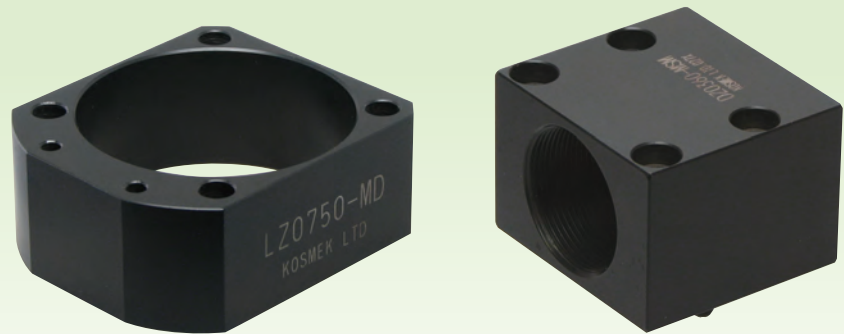

- **Manifold Block**

The mounting height of clamp is adjustable with the manifold block.

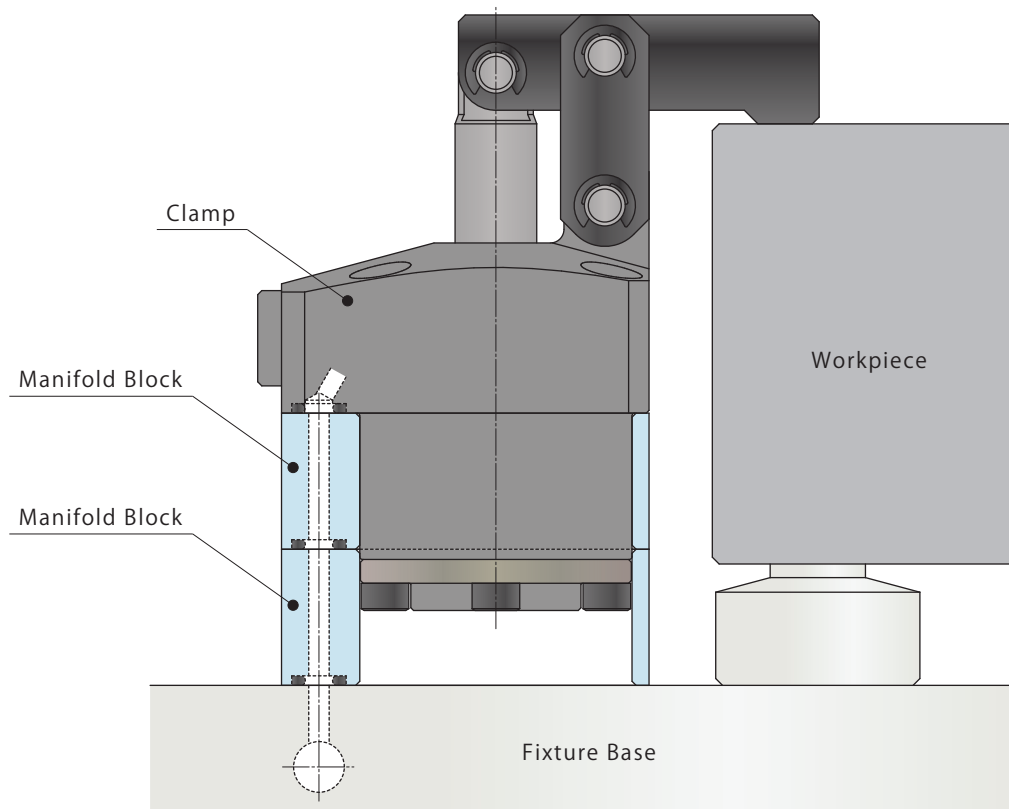

Applicable Model

Manifold Block Model No.	Corresponding Item Model No.
Model WHZ-MD	Model WCA Model WHA Model WCE Model WHE
Model LZY-MD	Model LKA Model LKE Model LHC Model LHS Model LKC Model LHA Model LHE Model LL
Model LZ-MS	Model LJ Model LG Model LM Model LT
Model LZ-MP	Model LC Model TC
Model TMZ-1MB	Model TMA-1
Model TMZ-2MB	Model TMA-2
Model DZ-MG□/MS□	Model DP

Application Examples

• Work Support (LC) Application Example

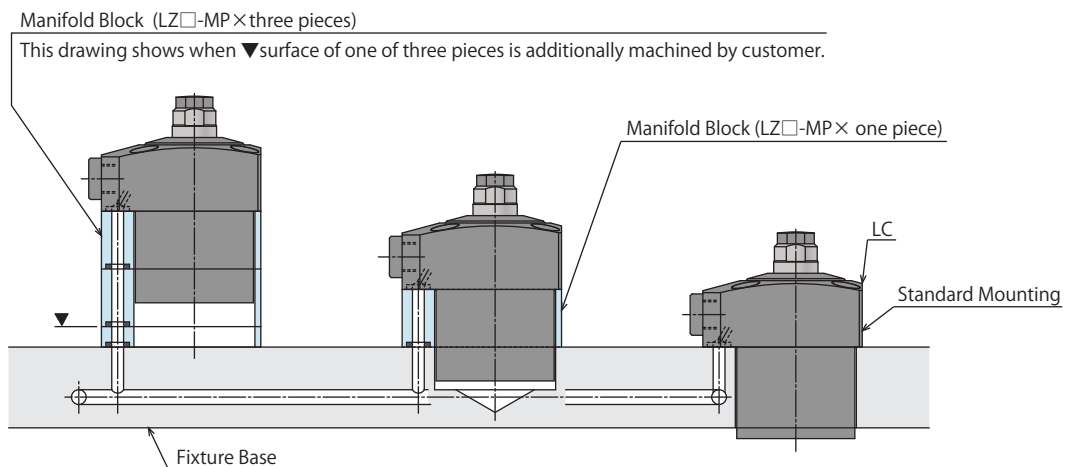

• Push Cylinder (DP) Application Example

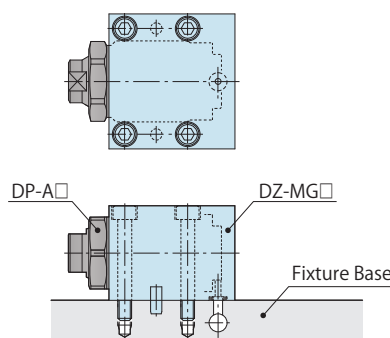

- High-Power Series
- Pneumatic Series
- Hydraulic Series
- Valve / Coupler Hydraulic Unit
- Manual Operation Accessories
- Cautions / Others

- Screw Locator
 - VXF/VXE
- Manual Expansion Locating Pin
 - VX

- Manifold Block
 - WHZ-MD
 - LZY-MD
 - LZ-MS
 - LZ-MP
 - TMZ-1MB
 - TMZ-2MB
 - DZ-M

- Manifold Block / Nut
 - DZ-R
 - DZ-C
 - DZ-P
 - DZ-B
 - LZ-S
 - LZ-SQ
 - WNZ-SQ
 - TNZ-S
 - TNZ-SQ

- Pressure Switch
 - JBA

- Pressure Gauge
 - JGA/JGB

- Manifold
 - JX

- Coupler Switch
 - PS

- G-Thread Fitting

Manifold Block for TMA-1

Model No. Indication

TMZ 040 0 - 1MB

Size
(Refer to following table)

Design No.
(Revision Number)

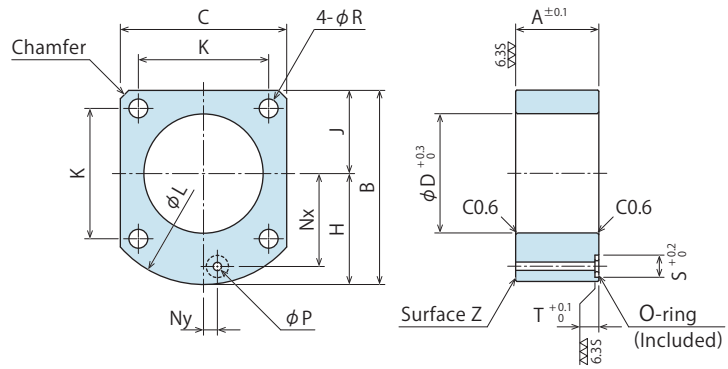

Model No.	TMZ0250-1MB	TMZ0400-1MB	TMZ0600-1MB	TMZ1000-1MB	TMZ1600-1MB	TMZ2500-1MB	TMZ3200-1MB
Corresponding Model No.	TMA0250-1	TMA0400-1	TMA0600-1	TMA1000-1	TMA1600-1	TMA2500-1	TMA3200-1
A	18	21	24	28	35	42	46
B	56.5	62	69	83	95	110	122
C	45	51	60	73	85	100	110
D	33	36	43	48	60	70	85
H	34	36.5	39	46.5	52.5	60	67
J	22.5	25.5	30	36.5	42.5	50	55
K	34	40	47	57	65	75	88
L	68	73	80	97	112	129	147
Nx	26	30	33.5	40	45	52.5	60
Ny	5	0	0	0	0	0	0
R	5.5	5.5	6.8	9	11	14	14
P	3	3	3	3	5	5	5
S	8	8	8	8	10	10	10
T	1.4	1.4	1.4	1.4	1.4	1.4	1.4
Chamfer	3	3	(φ80)	(φ97)	(φ112)	(φ129)	(φ147)
O-ring	1BP5	1BP5	1BP5	1BP5	1BP7	1BP7	1BP7
Weight kg	0.2	0.3	0.5	0.9	1.4	2.2	2.6

- Notes: 1. Material: S45C Surface Finishing: Alkaline Blackening
 2. Mounting bolts are not provided. Prepare mounting bolts according to the mounting height using the dimension A as a reference.
 3. For other block thickness (dim. A), machine the surface Z or design a block referring to the drawing and apply surface treatment if necessary.

Manifold Block for TMA-2

Model No. Indication

TMZ 040 0 - 2MB

Size
(Refer to following table)

Design No.
(Revision Number)

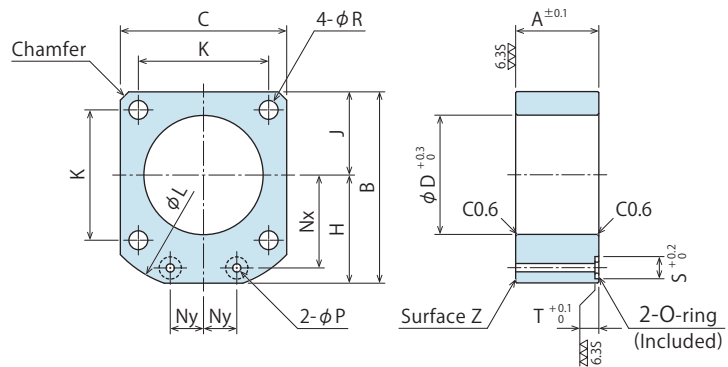

Model No.	TMZ0250-2MB	TMZ0400-2MB	TMZ0600-2MB	TMZ1000-2MB	TMZ1600-2MB	TMZ2500-2MB	TMZ3200-2MB
Corresponding Model No.	TMA0250-2	TMA0400-2	TMA0600-2	TMA1000-2	TMA1600-2	TMA2500-2	TMA3200-2
A	15	16	18	20	24	28	32
B	54	61	69	82.5	94.5	109.5	122
C	45	51	60	73	85	100	110
D	33	36	43	48	60	70	85
H	31.5	35.5	39	46	52	59.5	67
J	22.5	25.5	30	36.5	42.5	50	55
K	34	40	47	57	65	75	88
L	68	75	83	100	113	133	147
Nx	26	30	33.5	40	45	52.5	60
Ny	9	10	12	15	16	18.5	20
R	5.5	5.5	6.8	9	11	14	14
P	3	3	3	3	5	5	5
S	8	8	8	8	10	10	10
T	1.4	1.4	1.4	1.4	1.4	1.4	1.4
Chamfer	3	3	3	4	5	8	(φ147)
O-ring	1BP5	1BP5	1BP5	1BP5	1BP7	1BP7	1BP7
Weight kg	0.2	0.3	0.4	0.6	0.9	1.5	1.8

- Notes: 1. Material: S45C Surface Finishing: Alkaline Blackening
 2. Mounting bolts are not provided. Prepare mounting bolts according to the mounting height using the dimension A as a reference.
 3. For other block thickness (dim. A), machine the surface Z or design a block referring to the drawing and apply surface treatment if necessary.

Manifold Block for DP

Model No. Indication



※The drawing below shows DZ□0-MG□ (Gasket option).

※The drawing below shows DZ□0-MS□ (Piping option).

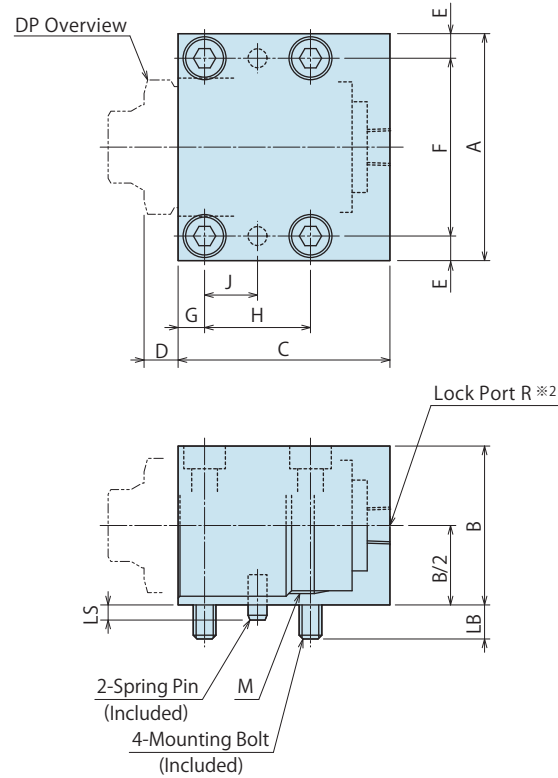
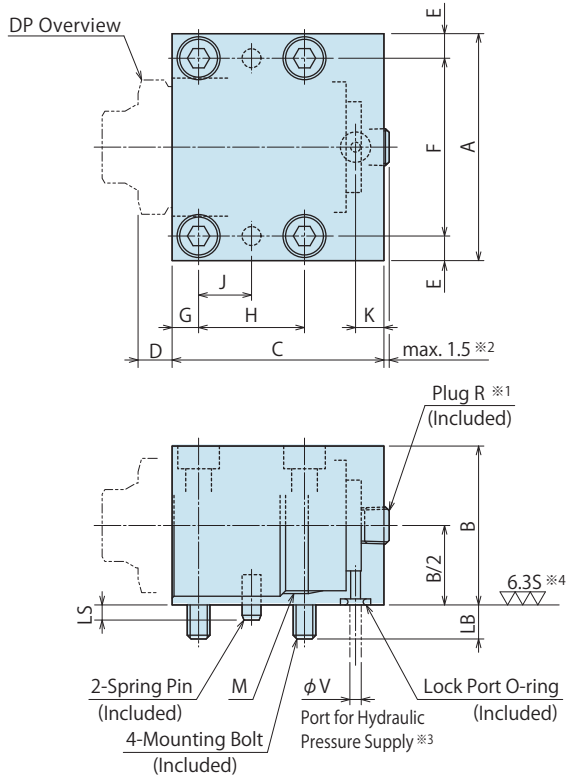

Notes :

- Material :S45C Surface Finishing :Alkaline Blackening
- G option: the R-thread plug is screwed in at shipment. There is variance in protrusion amount of the plug.
- Plug is not included in the S option.
- Recommended hole size for a hydraulic pressure supply port drilled by Customer.
Make sure there are no burrs around the connection and no cutting chips or other foreign substances inside.
- The surface touching the O-ring should have a roughness of $\sqrt{6.35}$.

Model No.		DZ0160-MG□	DZ0220-MG□	DZ0240-MG□	DZ0300-MG□	DZ0360-MG□	DZ0450-MG□	DZ0550-MG□	DZ0650-MG□	DZ0800-MG□
Stroke Code		S M L	S M L	S M L	S M L	S M L	S M L	S M L	S M L	S M L
Corresponding Model No.	Model No.	DP0160-□	DP0221-□	DP0241-□	DP0301-□	DP0361-□	DP0451-□	DP0551-□	DP0651-□	DP0801-□
	Stroke Code	S M L	S M L	S M L	S M L	S M L	S M L	S M L	S M L	S M L
A		32	38	45	50	60	75	90	105	120
B		22	28	32	38	42	52	62	72	88
C		34 40 49	32.5 38.5 51.5	35 42.5 59	38.5 45.5 65	43 56 77	50 63 85.5	56 69.5 92	65 79 108.5	70 88 119
D		6	8	8	9	9	13	13	15	15
E		4.5	4.5	6	6	6.5	8.5	10	11	11
F		23	29	33	38	47	58	70	83	98
G		5	5	6	6	7	8	9	11	11
H		12 18	12 18	12 18	16 22	18 28	20 30	24 36	30 42	34 52
J		6 9	6 9	6 9	8 11	9 14	10 15	12 18	15 21	17 26
K		7.5	7.5	7.5	7.5	7.5	11.5	11.5	11.5	11.5
LB		7	6	8	7	9	11	13	15	15
LS		3	3	3	4	4	4	4	6	7
M (Nominal × Pitch)		M16×1.5	M22×1.5	M24×1.5	M30×1.5	M36×1.5	M45×1.5	M55×2	M65×2	M80×2
R		Rc1/8	Rc1/8	Rc1/8	Rc1/8	Rc1/8	Rc1/4	Rc1/4	Rc1/4	Rc1/4
Mounting Bolt		M4×0.7×25	M4×0.7×30	M5×0.8×35	M5×0.8×40	M6×45	M8×55	M10×65	M12×75	M12×90
O-ring		1BP5	1BP5	1BP5	1BP5	1BP5	1BP7	1BP7	1BP7	1BP7
Spring Pin		φ3×8	φ3×8	φ3×8	φ5×12	φ5×12	φ6×12	φ6×12	φ8×16	φ10×20
V		3	3	3	5	5	5	5	5	5
Weight	kg	0.15 0.15 0.2	0.2 0.2 0.3	0.3 0.4 0.5	0.4 0.5 0.6	0.6 0.7 1	1 1.2 1.7	1.5 1.8 2.5	2.2 2.8 3.8	3.2 4 5.5

- High-Power Series
- Pneumatic Series
- Hydraulic Series
- Valve / Coupler Hydraulic Unit
- Manual Operation Accessories
- Cautions / Others

- Screw Locator
 - VXF/VXE
- Manual Expansion Locating Pin
 - VX

- Manifold Block
 - WHZ-MD
 - LZY-MD
 - LZ-MS
 - LZ-MP
 - TMZ-1MB
 - TMZ-2MB
 - DZ-M

- Manifold Block / Nut
 - DZ-R
 - DZ-C
 - DZ-P
 - DZ-B
 - LZ-S
 - LZ-SQ
 - WNZ-SQ
 - TNZ-S
 - TNZ-SQ

- Pressure Switch
 - JBA

- Pressure Gauge
 - JGA/JGB

- Manifold
 - JX

- Coupler Switch
 - PS

- G-Thread Fitting

Sales Offices

Sales Offices across the World

JAPAN HEAD OFFICE Overseas Sales	TEL. +81-78-991-5162	FAX. +81-78-991-8787
	KOSMEK LTD. 1-5, 2-chome, Murotani, Nishi-ku, Kobe-city, Hyogo, Japan 651-2241 〒651-2241 兵庫県神戸市西区室谷2丁目1番5号	
United States of America SUBSIDIARY KOSMEK (USA) LTD.	TEL. +1-630-620-7650	FAX. +1-630-620-9015
	650 Springer Drive, Lombard, IL 60148 USA	
MEXICO REPRESENTATIVE OFFICE KOSMEK USA Mexico Office	TEL. +52-442-161-2347	
	Av. Santa Fe #103 int 59 Col. Santa Fe Juriquilla C.P. 76230 Queretaro, Qro Mexico	
EUROPE SUBSIDIARY KOSMEK EUROPE GmbH	TEL. +43-463-287587	FAX. +43-463-287587-20
	Schleppeplatz 2 9020 Klagenfurt am Wörthersee Austria	
CHINA KOSMEK (CHINA) LTD. 考世美(上海)貿易有限公司	TEL. +86-21-54253000	FAX. +86-21-54253709
	Room601, RIVERSIDE PYRAMID No.55, Lane21, Pusan Rd, Pudong Shanghai 200125, China 中国上海市浦东新区浦三路21弄55号银亿滨江中心601室 200125	
INDIA BRANCH OFFICE KOSMEK LTD - INDIA	TEL. +91-9880561695	
	F 203, Level-2, First Floor, Prestige Center Point, Cunningham Road, Bangalore -560052 India	
THAILAND REPRESENTATIVE OFFICE KOSMEK Thailand Representation Office	TEL. +66-2-300-5132	FAX. +66-2-300-5133
	67 Soi 58, RAMA 9 Rd., Suanluang, Suanluang, Bangkok 10250, Thailand	
TAIWAN (Taiwan Exclusive Distributor) Full Life Trading Co., Ltd. 盈生貿易有限公司	TEL. +886-2-82261860	FAX. +886-2-82261890
	16F-4, No.2, Jian Ba Rd., Zhonghe District, New Taipei City Taiwan 23511 台湾新北市中和區建八路2號 16F-4 (遠東世紀廣場)	
PHILIPPINES (Philippines Exclusive Distributor) G.E.T. Inc, Phil.	TEL. +63-2-310-7286	FAX. +63-2-310-7286
	Victoria Wave Special Economic Zone Mt. Apo Building, Brgy. 186, North Caloocan City, Metro Manila, Philippines 1427	
INDONESIA (Indonesia Exclusive Distributor) PT. Yamata Machinery	TEL. +62-21-29628607	FAX. +62-21-29628608
	Delta Commercial Park I, Jl. Kenari Raya B-08, Desa Jayamukti, Kec. Cikarang Pusat Kab. Bekasi 17530 Indonesia	

Sales Offices in Japan

Head Office Osaka Sales Office Overseas Sales	TEL. 078-991-5162	FAX. 078-991-8787
	〒651-2241 兵庫県神戸市西区室谷2丁目1番5号	
Tokyo Sales Office	TEL. 048-652-8839	FAX. 048-652-8828
	〒331-0815 埼玉県さいたま市北区大成町4丁目81番地	
Nagoya Sales Office	TEL. 0566-74-8778	FAX. 0566-74-8808
	〒446-0076 愛知県安城市美園町2丁目10番地1	
Fukuoka Sales Office	TEL. 092-433-0424	FAX. 092-433-0426
	〒812-0006 福岡県福岡市博多区上牟田1丁目8-10-101	

Global Network

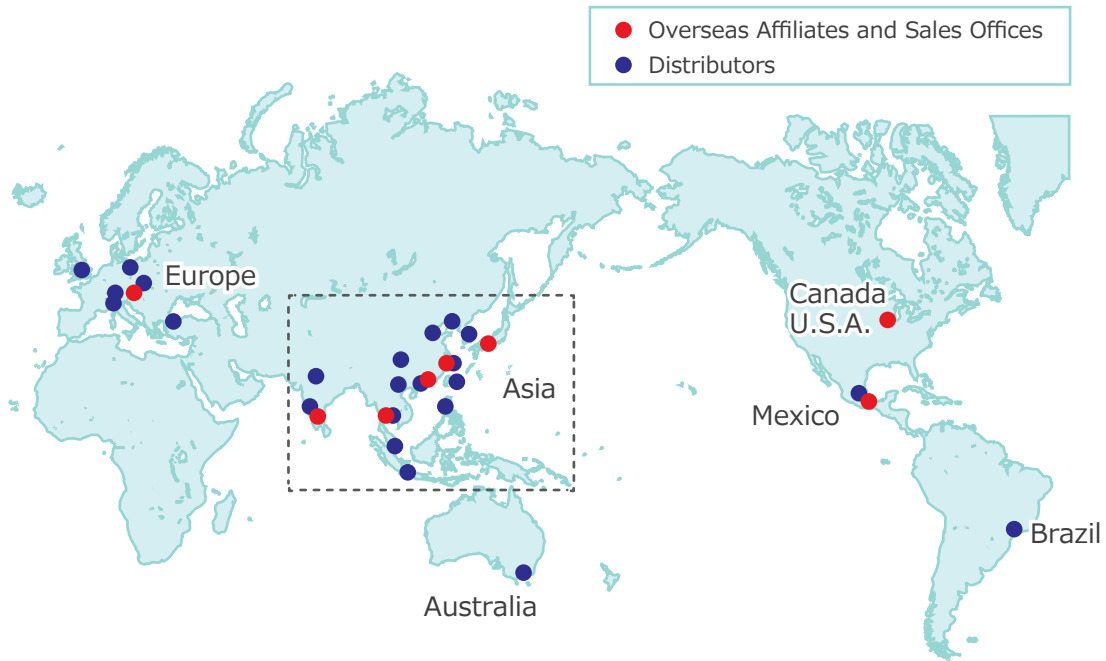

Asia Detailed Map



WAHLTEC GmbH
 T: +49 (7584) 9238883
 F: +49 (7584) 9238887
 kosmek@wahltec.de
 www.wahltec.de



● FOR FURTHER INFORMATION ON UNLISTED SPECIFICATIONS AND SIZES, PLEASE CALL US.
 ● SPECIFICATIONS IN THIS CATALOG ARE SUBJECT TO CHANGE WITHOUT NOTICE.

