

Leakless Coupler

Model JWC/JWD

100% Stainless Steel

※ No copper (Cu) or zinc (Zn) based materials are used. Stainless steel and aluminum materials may contain copper (Cu) and zinc (Zn) as additive elements.



Leakless Coupler To Solve Pallet Transfer Problems

No need to provide air pressure when disconnected from air source. Leakless coupler can be disconnected while pressure is provided. Enables to remain air clamps in a locked state and transfer a workpiece to the next station.

1 Load and clamp a workpiece

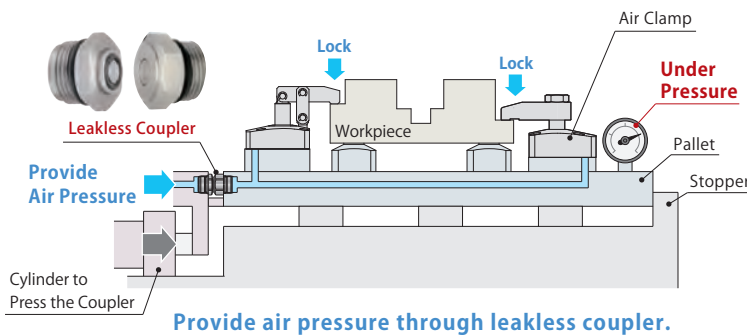

2 Transfer a pallet

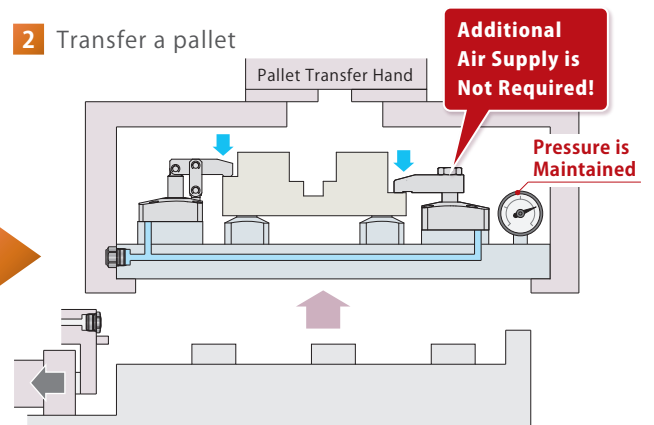

Disconnect couplers under pressure. The couplers can maintain the air pressure inside the circuit. Not necessary to provide the air pressure during pallet transfer. Easy robot teaching without air tubing.

3 Intermediate Process (Machining, Deburring, Press-fit, Inspection etc.)

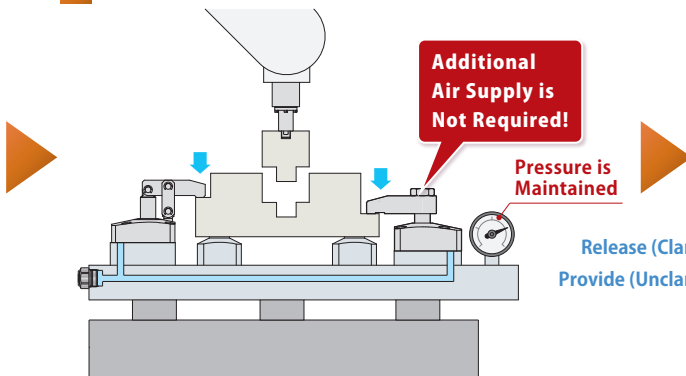

Possible to transfer a pallet to the next station while clamp is in a locked state.

4 Unload a workpiece

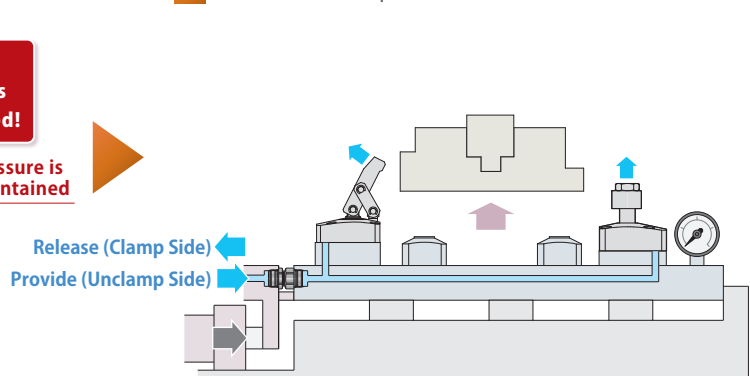

After the operation is completed, connect couplers to release air out. (Provide air pressure to unclamp port to unload a workpiece.)

Enables to **maintain clamping force** since it keeps the air pressure **even if a coupler is disconnected**



※ Usable for negative pressure. Please contact us.

Locating + Clamp

Locating

Hand • Clamp

Support

Valve • Coupler

Electric Drive • Conveyor

Cautions • Others

Air Safety Valve

BWS

Air Sequence Valve

BWD

Auto Coupler

JVA/JVB0100

JVA/JVB0201

JVA/JVB0301

JVC/JVD

JVE/JVF

JNA/JNB

JNC/JND

JLP/JLS

JTA/JTB

Leakless Coupler

JWC/JWD

Rotary Joint

JR

Action Description

※ Action Description when connecting/disconnecting Leakless Coupler under pressure.

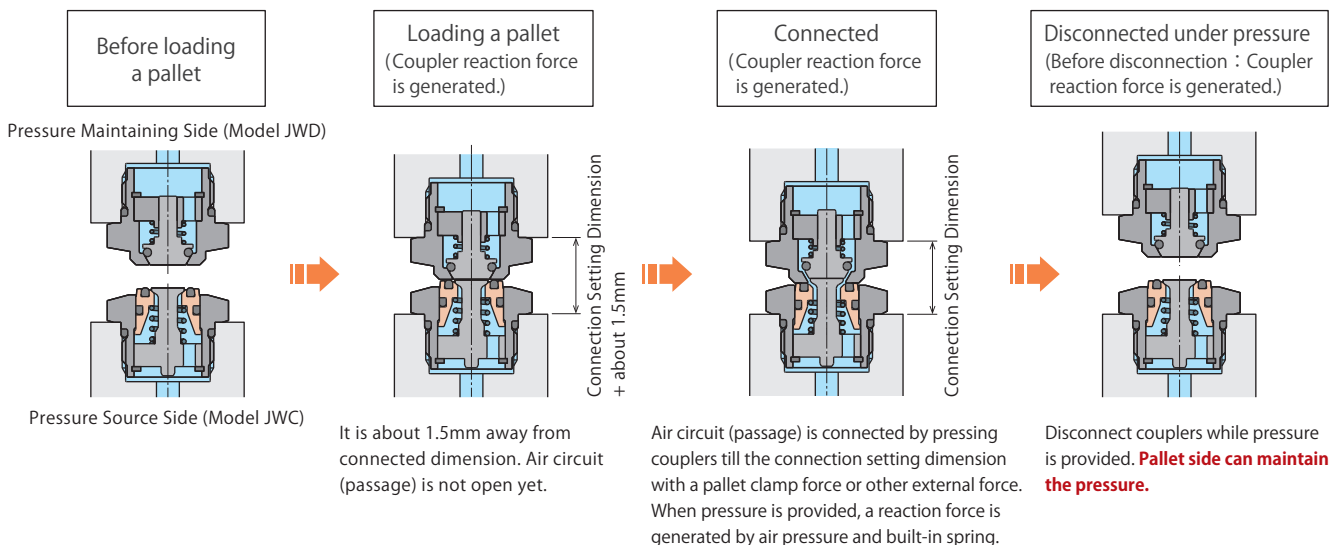

Air Pressure Maintaining Test Data

● KOSMEK internal test data to verify pressure maintaining for 48 hours

Testing data of measuring elapsed time and pressure change when Leakless Coupler is disconnected. Sealing part is equipped with Soft Seal. It enables a great pressure maintaining ability.

※ Testing data with stable surrounding temperature.

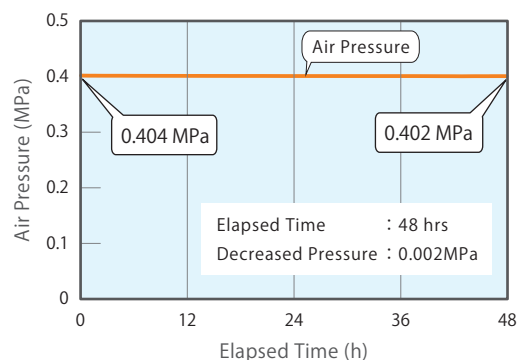

Model No. Indication

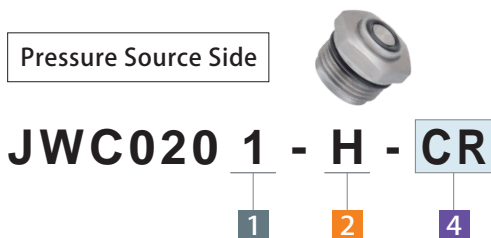

1 Design No.

1 : Revision Number

2 Material

H : Stainless Steel, Fluor Rubber

3 Connection Setting Dimension

- B02** : D=11.5 mm (when using with SWTB020 / VSB020)
- B06** : D=13 mm (when using with SWTB030 / VSB060)
- B10** : D=15.5 mm (when using with SWTB050 / VSB100)
- J01** : D=17 mm (when using with SWTJ010)
- J02** : D=20 mm (when using with SWTJ020 / VSJ020)
- J06** : D=23.5 mm (when using with SWTJ030 / VSJ060)
- J10** : D=26 mm (when using with SWTJ050 / VSJ100)

※ When not using with a location clamp or a pallet clamp, please select the model number from the Dimension List on the next page.
 ※ Please contact us when using with Hydraulic Double Acting Pallet Clamp (model VT).

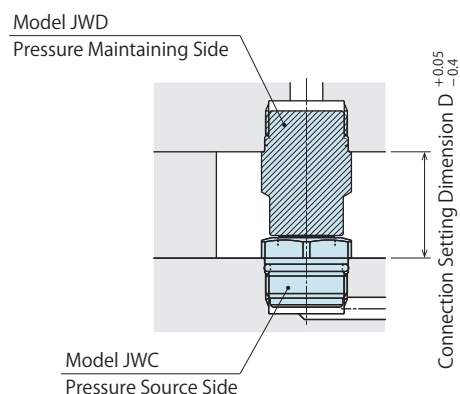

4 Grease

- Blank** : NBU8EP made by NOK KLUEBER (Standard)
- CR** : AFF made by THK (For clean environment)
- FD** : NH1 64-422 made by NOK KLUEBER (For food machinery)

Specifications

Model No.	Pressure Source Side		JWC0201-H-□						
	Pressure Maintaining Side		JWD0201	JWD0201	JWD0201	JWD0201	JWD0201	JWD0201	JWD0201
			-H-SJ01-□	-H-SB02-□	-H-SJ02-□	-H-SB06-□	-H-SJ06-□	-H-SB10-□	-H-SJ10-□
Max. Operating Pressure	MPa		0.5 ^{※1}						
Withstanding Pressure	MPa		1.0						
Min. Passage Area	mm ²		12.6						
Offset Tolerance	mm		±0.5						
Angle Error Tolerance	DEG.		0.3						
Operating Temperature	°C		0 ~ 120						
Usable Fluid			Positive air pressure, Negative air pressure						
Reaction Force	N	Op. Pressure	at 0.5 MPa	125					
			at 0.3 MPa	94					
			at P MPa	154 × P + 48					
Weight	g		JWC						
			JWD	45	32	46	36	49	41
Applicable Clamp Model	SWT	SWT0010	SWT0020		SWT0030		SWT0050		
	WVS	—	WVS0040		WVS0060		WVS0100		
	VS	—	VS0020/VS0040		VS0060		VS0100		
Applicable Block Model	Block for SWT	SWTJ010	SWTB020	SWTJ020	SWTB030	SWTJ030	SWTB050	SWTJ050	
	Block for WVS/VS	—	VSB020	VSJ020	VSB060	VSJ060	VSB100	VSJ100	

Note :

※1. Usable for negative pressure. Please contact us.

Circuit Symbol

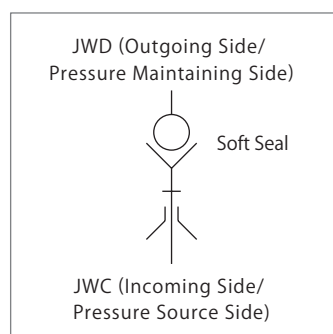

Supply Pressure–Reaction Force Graph

It shows reaction force at pressurized state.

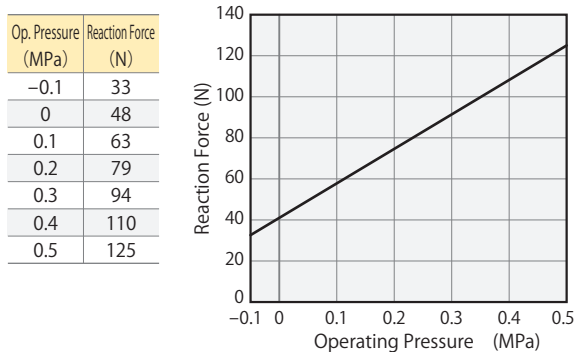

Flow Rate–Pressure Loss Characteristic Graph

The fluid used on this data is air (25°C).

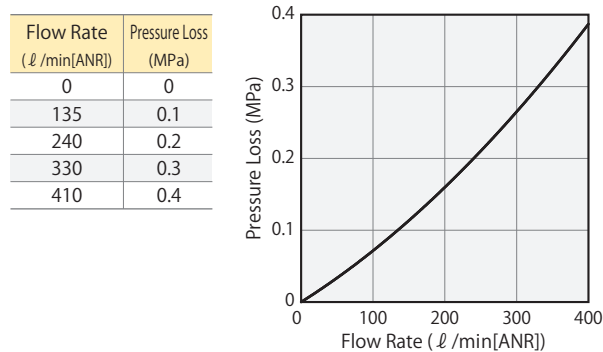

External Dimensions (JWC/JWD)

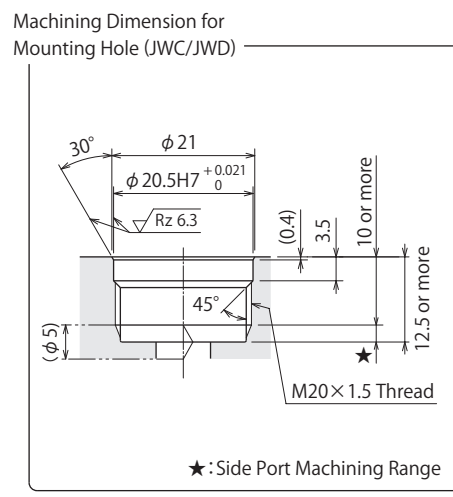
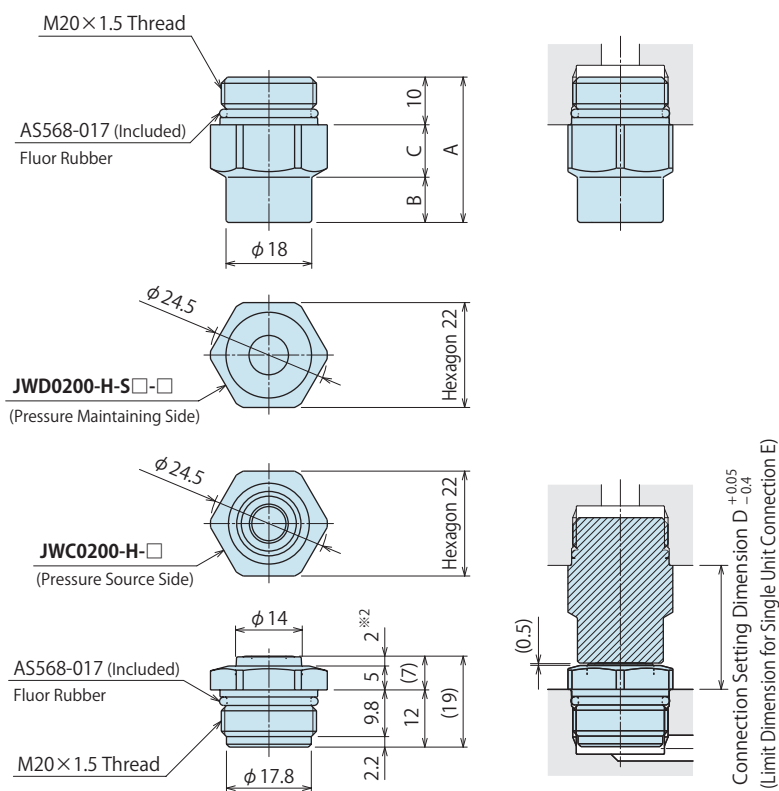

Model No.	Thread Size	Tightening Torque (N·m)
JWC0201-H-□ JWD0201-H-S-□	M20×1.5	25

Dimension List (mm)

Model No.	JWC0201-H-□						
Pressure Source Side							
Model No.	JWD0201-H-SJ01-□	JWD0201-H-SB02-□	JWD0201-H-SJ02-□	JWD0201-H-SB06-□	JWD0201-H-SJ06-□	JWD0201-H-SB10-□	JWD0201-H-SJ10-□
A	21.5	16	24.5	17.5	28	20	30.5
B	1	1	3.5	1	7	1	9.5
C	10.5	5	11	6.5	11	9	11
D	17	11.5	20	13	23.5	15.5	26
E	16.5	11	19.5	12.5	23	15	25.5

Note:

- ※2 in the JWC dimension shows when air pressure is provided at disconnected state. (About 0.5mm retracted when air pressure is not provided.)

Application Example : Using with Location Clamp / Pallet Clamp

Leakless Coupler can be connected by Location Clamp / Pallet Clamp.

When auto couplers get connected/separated using pallet clamps under pressure, please lock the clamps with the reaction force shown in the specification.

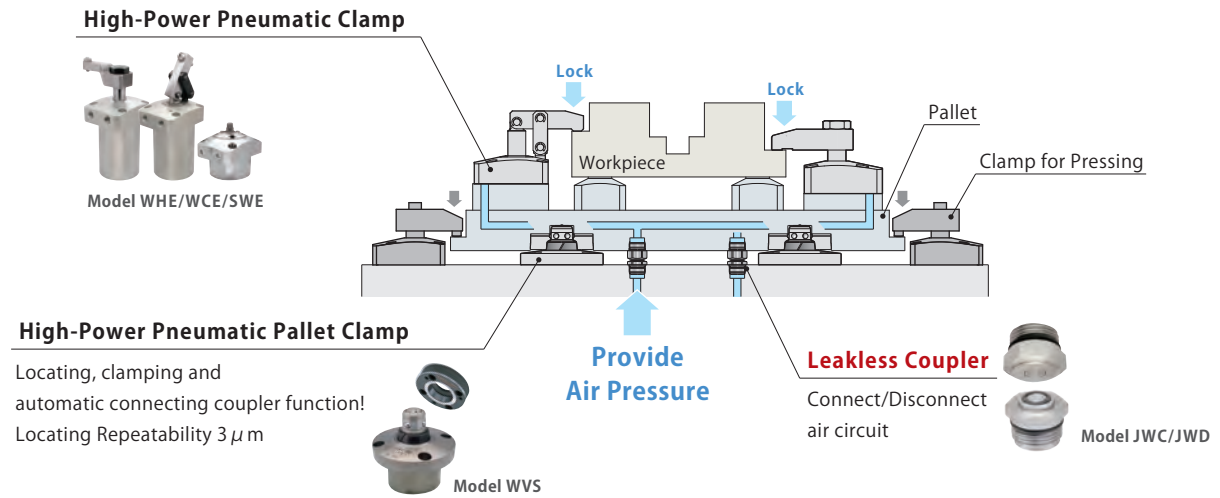

Connected State Dimension when Using with Location Clamp / Pallet Clamp

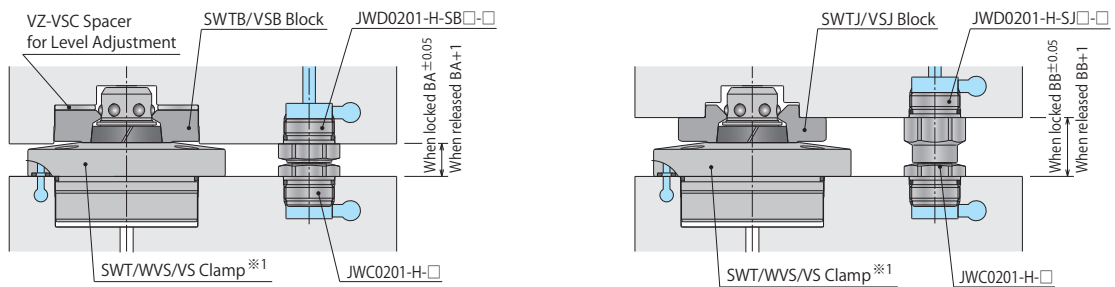

Connected State Dimension List when Using with Location Clamp/Pallet Clamp (mm)

Clamp Model No.	SWT0010	SWT0020 WVS0040 VS0020/VS0040	SWT0030 WVS0060 VS0060	SWT0050 WVS0100 VS0100
When using SWTB / VSB Block BA	-	11.5	13	15.5
When using SWTJ / VSJ Block BB	17	20	23.5	26

Note :

※1. This drawing shows when using SWT.

Reference Connection Drawing when Using SWTB010
Spot facing shown in the below drawing is required only when using JWC/JWD with the combination of SWT0010 and SWTB010.

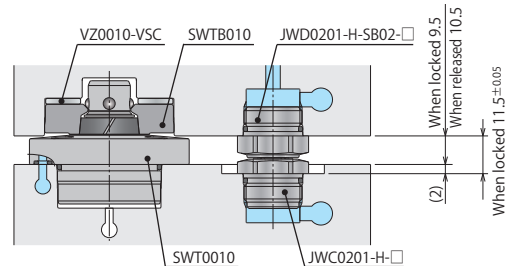

● Cautions (JWC/JWD)

1. When maintaining pressure in JWD after disconnecting under pressure, make sure the device has a method and condition that it can connect with a greater force than a reaction force.

Even when using with Pallet Clamp / Location Clamp, it is required to press with a greater force than a reaction force before locking action.

2. Do not use a device or coupler that might leak in the pressure maintaining circuit.
3. JWD cannot maintain pressure when the check valve is contaminated.
4. Since JWC is a metal seal, there may be slight air leakage when pressurized under disconnected state.
5. Do not connect the coupler when each connecting surface is contaminated.
When there are cutting chips or coolant, install a cover or remove all contaminants with air blow.
6. Exceeding allowable offset leads to damage on internal parts. It is recommended to install a guide pin.
(This may also cause air leakage when disconnected under pressure.)
7. When pressing to the connection limit, a pressing force should be higher than a reaction force and lower than 4.0kN.
8. It is recommended to set a pressure gauge to a pressure maintaining circuit.

● Circuit Reference

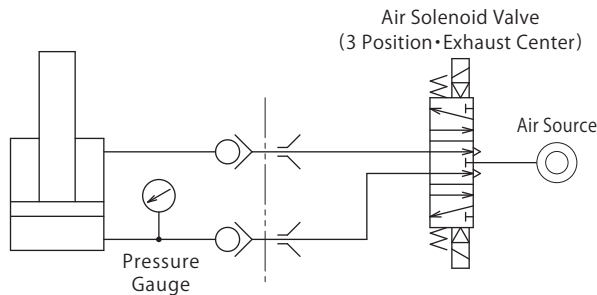

There may be a slight air leak when the coupler on the pressure source side is pressurized under disconnected state. In order to stop air pressure on the pressure source side after disconnected under pressure, it is recommended to use a three-position exhaust center for a circuit control air solenoid valve. (Able to decrease pressure on both sides to 0MPa for maintenance.)

However, when the coupler is connected at the exhaust center state, the air on the pressure maintaining side will be released at the same time when the coupler is connected.

Locating + Clamp

Locating

Hand • Clamp

Support

Valve • Coupler

Electric Drive • Conveyor

Cautions • Others

Air Safety Valve

BWS

Air Sequence Valve

BWD

Auto Coupler

JVA/JVB0100

JVA/JVB0201

JVA/JVB0301

JVC/JVD

JVE/JVF

JNA/JNB

JNC/JND

JLP/JLS

JTA/JTB

Leakless Coupler

JWC/JWD

Rotary Joint

JR

● Cautions

● Notes on Handling

- 1) It should be operated by qualified personnel.
 - The hydraulic machine and air compressor should be operated and maintained by qualified personnel.
- 2) Do not operate or remove the product unless the safety protocols are ensured.
 - ① The machine and equipment can only be inspected or prepared when it is confirmed that the safety devices are in place.
 - ② Before the product is removed, make sure that the above-mentioned safety devices are in place. Shut off the pressure and power source, and make sure no pressure exists in the air and hydraulic circuits.
 - ③ After stopping the product, do not remove until the temperature drops.
 - ④ Make sure there is no trouble/issue in the bolts and respective parts before restarting the machine or equipment.
- 3) Do not touch a clamp (cylinder) while it is working. Otherwise, your hands may be injured.



- 4) Do not disassemble or modify.
 - If the equipment is taken apart or modified, the warranty will be voided even within the warranty period.

● Maintenance and Inspection

- 1) Removal of the Machine and Shut-off of Pressure Source
 - Before removing the product, make sure that the safety devices are in place. Shut off the pressure and power source and make sure no pressure exists in the air and hydraulic circuits.
 - Make sure there is no trouble/issue in the bolts and respective parts before restarting.
- 2) Regularly clean the area around the piston rod and plunger.
 - If it is used when the surface is contaminated with dirt, it may lead to packing seal damage, malfunctioning, fluid leakage.

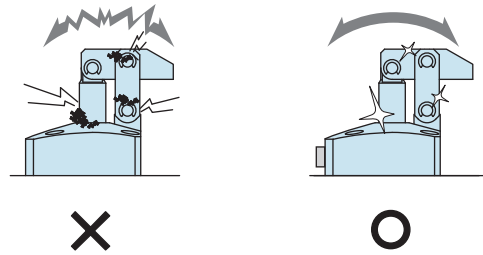

- 3) Regularly clean the reference surfaces (taper reference surface and seating surface) of locating products (SWT/SWQ/SWP/VRA/VRC/VX/VXE/VXF/WVS/WVG/VWH/VWM/VWK).
 - Locating products (except VRA/VRC/VX/VXE/VXF and SWR without air blow port) can remove contaminants with the cleaning function. When installing a workpiece or a pallet, make sure there are no contaminants such as thick sludge.
 - Continuous use with dirt on components will lead to locating failure, fluid leakage and malfunction.

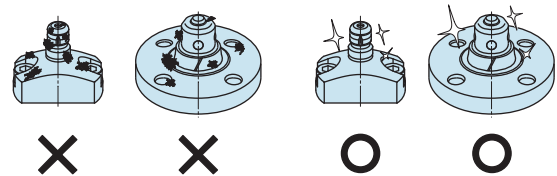

- 4) Regularly tighten pipe, mounting bolt, nut, snap ring, cylinder and others to ensure proper use.
- 5) Make sure the hydraulic fluid has not deteriorated.
- 6) Make sure there is a smooth action without an irregular noise.
 - Especially when it is restarted after left unused for a long period, make sure it can be operated correctly.
- 7) The products should be stored in the cool and dark place without direct sunshine or moisture.
- 8) Please contact us for overhaul and repair.

● Warranty

1) Warranty Period

- The product warranty period is 18 months from shipment from our factory or 12 months from initial use, whichever is earlier.

2) Warranty Scope

- If the product is damaged or malfunctions during the warranty period due to faulty design, materials or workmanship, we will replace or repair the defective part at our expense. Defects or failures caused by the following are not covered.

- ① If the stipulated maintenance and inspection are not carried out.
- ② Failure caused by the use of the non-confirming state at the user's discretion.
- ③ If it is used or operated in an inappropriate way by the operator. (Including damage caused by the misconduct of the third party.)
- ④ If the defect is caused by reasons other than our responsibility.
- ⑤ If repair or modifications are carried out by anyone other than Kosmek, or without our approval and confirmation, it will void warranty.
- ⑥ Other caused by natural disasters or calamities not attributable to our company.
- ⑦ Parts or replacement expenses due to parts consumption and deterioration. (Such as rubber, plastic, seal material and some electric components.)

Damages excluding from direct result of a product defect shall be excluded from the warranty.

[Locating + Clamp](#)
[Locating](#)
[Hand · Clamp](#)
[Support](#)
[Valve · Coupler](#)
[Electric Drive · Conveyor](#)
[Cautions · Others](#)

Cautions

[Installation Notes](#)
[Maintenance/Inspection](#)
[Warranty](#)
[表記改定のお知らせ](#)

Company Profile

[Company Profile](#)
[Our Products](#)
[History](#)

Index

[Search by Alphabetical Order](#)
[Sales Offices](#)

Sales Offices

Sales Offices across the World

JAPAN HEAD OFFICE Overseas Sales	TEL. +81-78-991-5162 FAX. +81-78-991-8787 KOSMEK LTD. 1-5, 2-chome, Murotani, Nishi-ku, Kobe-city, Hyogo, Japan 651-2241 〒651-2241 兵庫県神戸市西区室谷2丁目1番5号
United States of America SUBSIDIARY KOSMEK (USA) LTD.	TEL. +1-630-620-7650 FAX. +1-630-620-9015 650 Springer Drive, Lombard, IL 60148 USA
MEXICO REPRESENTATIVE OFFICE KOSMEK USA Mexico Office	TEL. +52-442-161-2347 Av. Santa Fe #103 int 59 Col. Santa Fe Juriquilla C.P. 76230 Queretaro, Qro Mexico
EUROPE SUBSIDIARY KOSMEK EUROPE GmbH	TEL. +43-463-287587 FAX. +43-463-287587-20 Schleppeplatz 2 9020 Klagenfurt am Wörthersee Austria
CHINA KOSMEK (CHINA) LTD. 考世美(上海)貿易有限公司	 TEL. +86-21-54253709 21, Pusan Rd, Pudong Shanghai 200125, China 601室 200125
INDIA BRANCH OFFICE KOSMEK LTD - INDIA	WAHLTEC GmbH Ravensburger Str. 14 88361 Altshausen T: +49 (7584) 9238883 F: +49 (7584) 9238887 www.wahltec.de 21, Cunningham Road, Bangalore -560052 India
THAILAND REPRESENTATIVE OFFICE KOSMEK Thailand Representation Office	FAX. +66-2-300-5133 g, Bangkok 10250, Thailand
TAIWAN (Taiwan Exclusive Distributor) Full Life Trading Co., Ltd. 盈生貿易有限公司	FAX. +886-2-82261890 16F-4, No.2, Jian Ba Rd., Zhonghe District, New Taipei City Taiwan 23511 台湾新北市中和區建八路2號 16F-4 (遠東世紀廣場)
PHILIPPINES (Philippines Exclusive Distributor) G.E.T. Inc, Phil.	TEL. +63-2-310-7286 FAX. +63-2-310-7286 Victoria Wave Special Economic Zone Mt. Apo Building, Brgy. 186, North Caloocan City, Metro Manila, Philippines 1427
INDONESIA (Indonesia Exclusive Distributor) PT. Yamata Machinery	TEL. +62-21-29628607 FAX. +62-21-29628608 Delta Commercial Park I, Jl. Kenari Raya B-08, Desa Jayamukti, Kec. Cikarang Pusat Kab. Bekasi 17530 Indonesia

Sales Offices in Japan

Head Office Osaka Sales Office Overseas Sales	TEL. 078-991-5162 FAX. 078-991-8787 〒651-2241 兵庫県神戸市西区室谷2丁目1番5号
Tokyo Sales Office	TEL. 048-652-8839 FAX. 048-652-8828 〒331-0815 埼玉県さいたま市北区大成町4丁目81番地
Nagoya Sales Office	TEL. 0566-74-8778 FAX. 0566-74-8808 〒446-0076 愛知県安城市美園町2丁目10番地1
Fukuoka Sales Office	TEL. 092-433-0424 FAX. 092-433-0426 〒812-0006 福岡県福岡市博多区上牟田1丁目8-10-101

Global Network

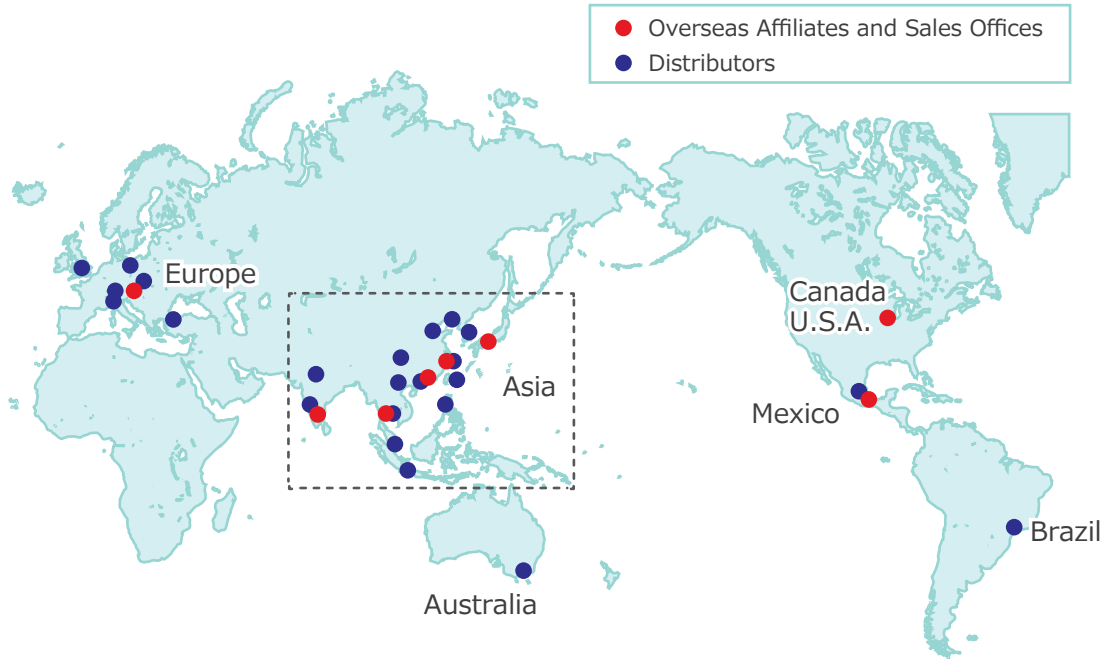

Asia Detailed Map

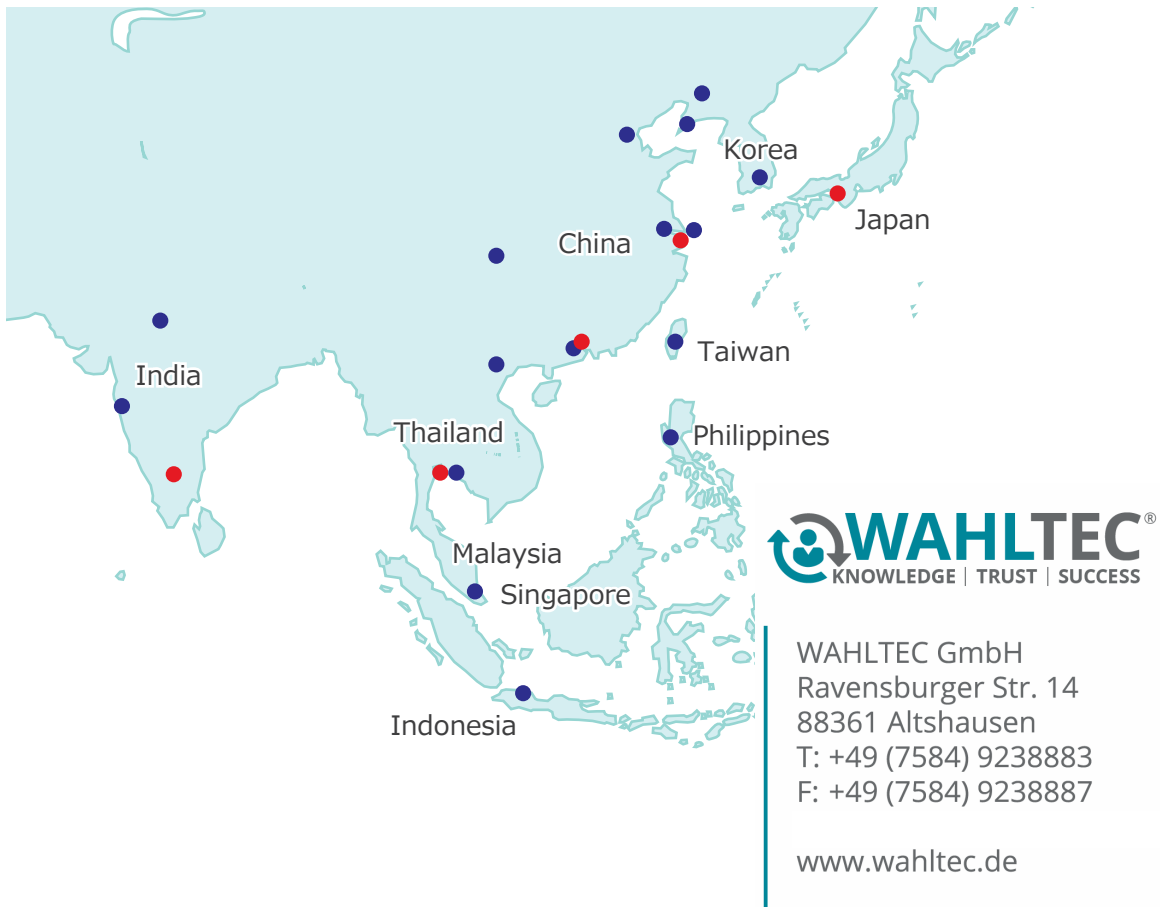

● FOR FURTHER INFORMATION ON UNLISTED SPECIFICATIONS AND SIZES, PLEASE CALL US.
● SPECIFICATIONS IN THIS CATALOG ARE SUBJECT TO CHANGE WITHOUT NOTICE.

