

Auto Backup Pin

Model WDC



Prevents Chattering and Distortion Counter to the Load

Pin Touches Workpiece Softly and Stops to Provide Support

Before

With No Backup

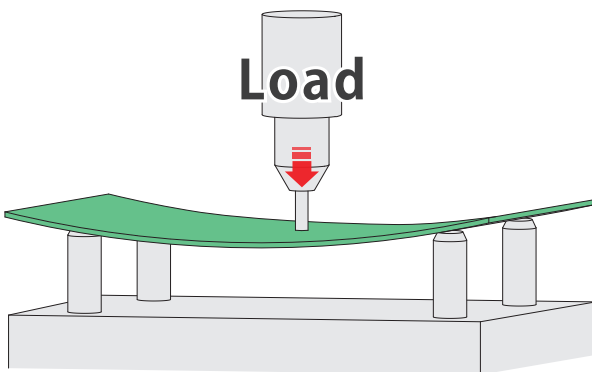

Chattering

Chattering on base plate, molding and workpiece due to the work load.

After

With Backup

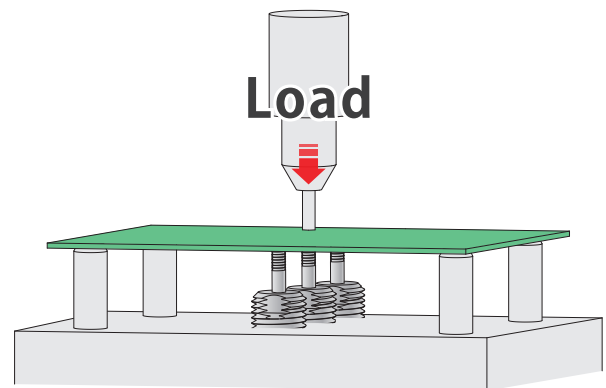

Prevents Chattering

Prevention of chattering from the load enables high-quality implementation and processing. (The pin touches workpiece softly and holds it instantly.)

Productivity Improvement • Cost Reduction : From Manual to Automatic

After

Automatic Following of the Height

The pin (plunger) descends and reaches the reference surface by the workpiece weight (slight force). Since the pin descends according to workpiece, it can absorb the height tolerance of workpiece and instantly complete the height adjustment. Time reduction in setup improves machine availability.

Before

No Time Saving (Manual Type)

Minute adjustment in unreachable or non-visible places is difficult and takes time.

Manual Adjustment with a Screw

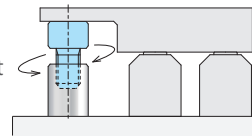

Pin descends according to workpiece.

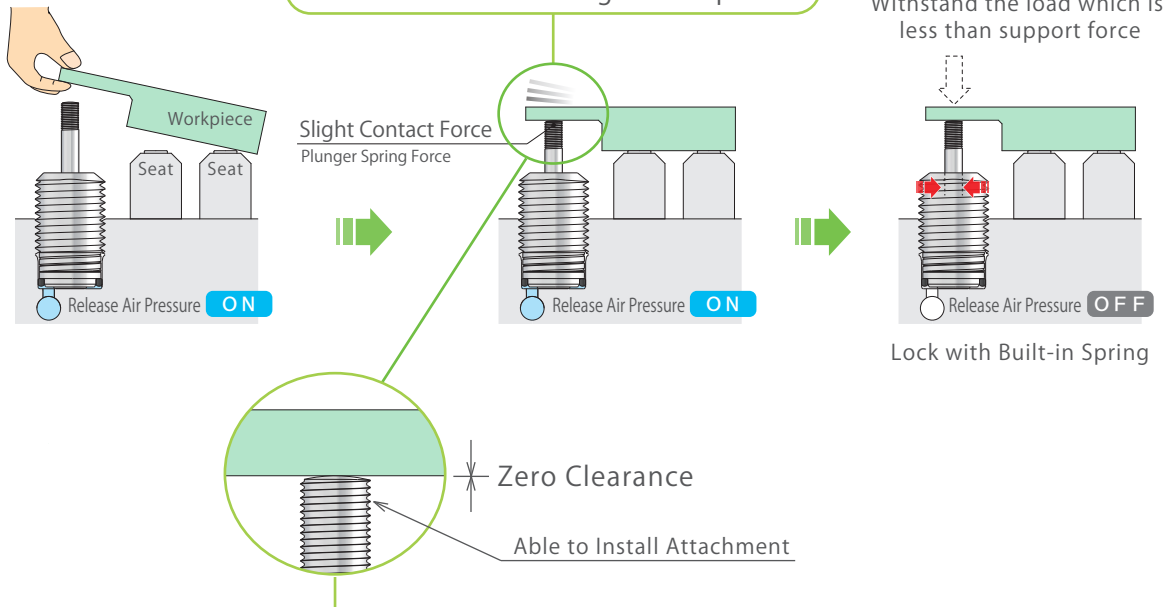

Withstand the load which is less than support force

Lock with Built-in Spring

Quality Improvement • Yield Rate Reduction : Suitable for the Work Required of Accuracy

After

Zero Clearance

It enables high-accuracy implementation and yield rate reduction, since there is no clearance regardless of the variation in height caused by workpiece distortion, the gap between seat surface and tip of the pin, or solid difference.

Before

Chattering

General fixed backup pin tends to have chattering due to the variation in height caused by workpiece distortion, the gap between seat surface and tip of the pin, or individual differences in pin height. Chattering causes low accuracy and assembling failure. Moreover, every time component changes, the backup pin has to be changed.

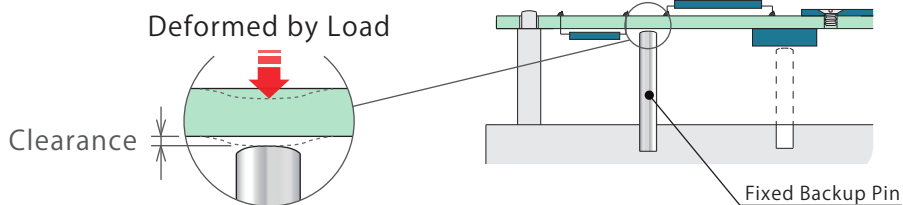

Locating + Clamp

Locating

Hand • Clamp

Support

Valve • Coupler

Cautions • Others

Auto Backup Pin

WDC

High-Power Pneumatic Work Support

WNC

Pneumatic Work Support Rodless Hollow

WNA

Manifold Block/Nut

DZ-R

DZ-C

LZ-S

WNZ-SQ

● Action Description

※ The internal structure is a simplified figure. Actual components are different.

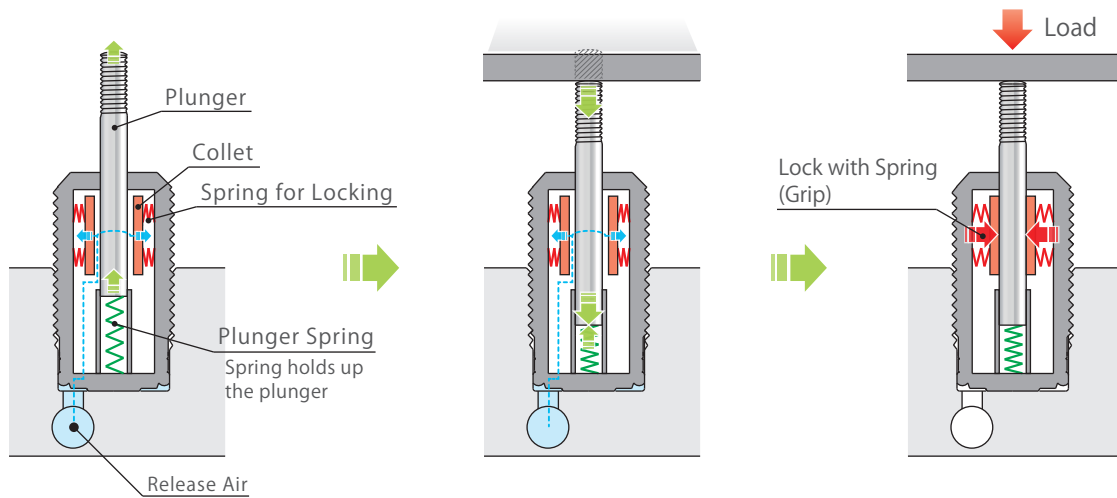

Before setting (When releasing)

Release Air Pressure **ON**

Supply release air pressure to unlock the plunger. The plunger lifts up to the stroke-end by plunger spring.

When setting workpiece

Release Air Pressure **ON**

Set a workpiece. The plunger goes down due to the weight of the workpiece.
 ※The plunger does not go down when plunger spring force is stronger than the workpiece weight.

When supporting

Release Air Pressure **OFF**

When release air pressure is OFF, the collet locks the plunger securely with the spring for locking. It withstands the load which is lower than support force.

● Application Examples

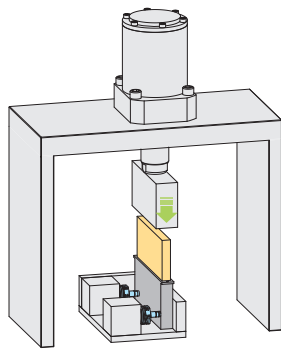

Press-Fit Machine

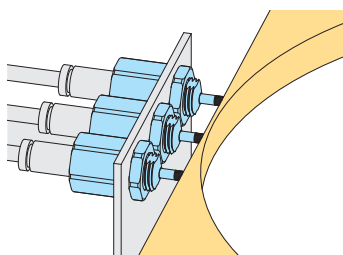
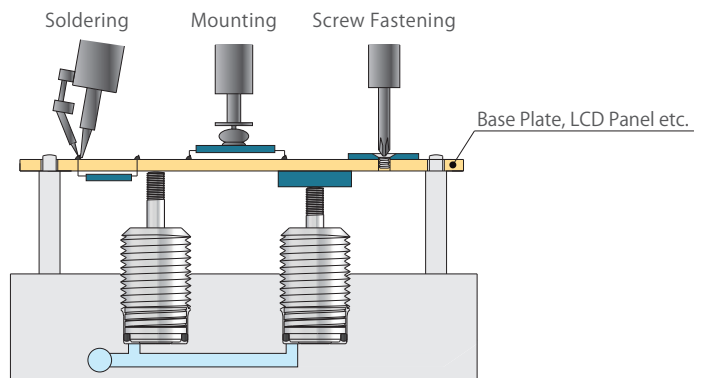

Thin-walled Section

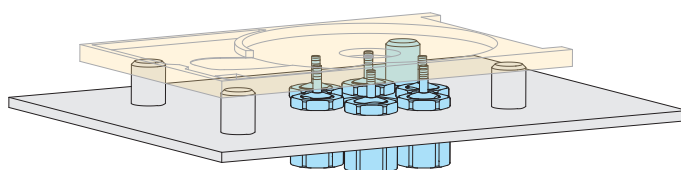

HDD Installation • Press Fit

Model No. Indication

WDC00 3 0 - E

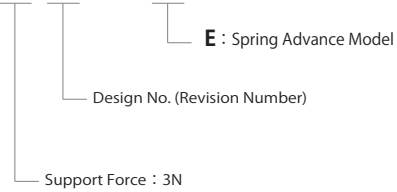

Specifications

Model No.	WDC0030-E	
Support Force ※1	N	3
Plunger Stroke	mm	4
Cylinder Capacity	mm ³	19
Plunger Spring Force※2	N	0.1 ~ 0.3
Max. Operating Pressure	MPa	0.7
Min. Operating Pressure	MPa	0.35
Withstanding Pressure	MPa	1.0
Operating Temperature	°C	0 ~ 70
Usable Fluid	Dry Air	
Recommended Tightening Torque for Main Body N•m	2	
Weight	g	7

External Dimensions

※The drawing shows the released state of WDC0030-E.

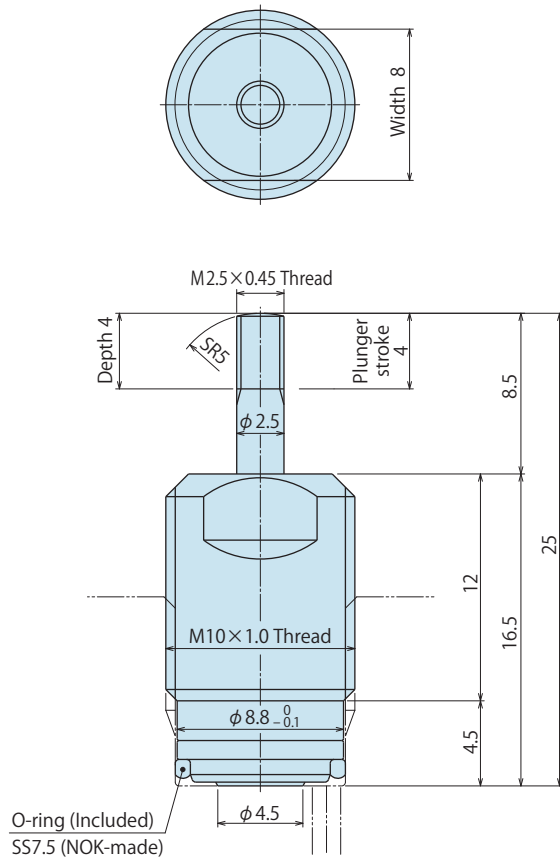

Machining Dimension for Recommended Mounting Hole

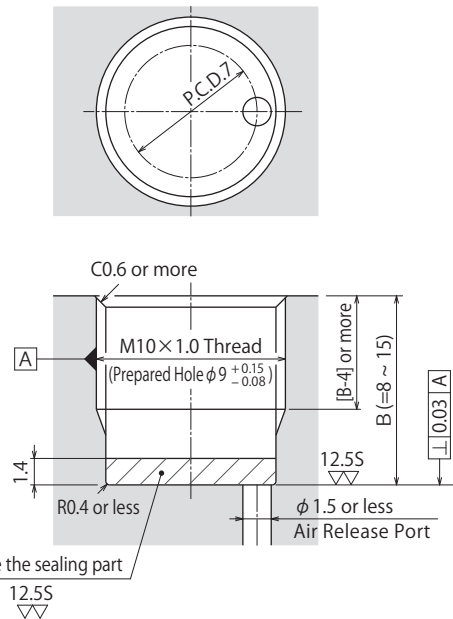

Make sure not to damage the sealing part

Hatched Area 12.55

Accessories : Manifold Block for Mounting

Please contact us for further information.



Cautions

- ※1. This product performs lock action with spring and release action with air pressure; therefore, support force is constant.
- ※2. Prepare the stopper for a thin and light workpiece if necessary.

When using multiple backup pins, a workpiece may be pushed up by plunger spring force.

1. When mounting an attachment on the tip of plunger, the load ratio to the plunger spring force has to be 30% or less. (Plunger direction either vertical or horizontal: the load ratio has to be 30% or less.)

Ex.) Plunger spring force=0.1-0.3N

Attachment maximum weight = $0.1 \times 0.3 / 0.009807 = 3g$

However, the calculated value may differ due to the plunger sliding friction and spring specific etc., so the load ratio should be low as much as possible.

Locating + Clamp

Locating

Hand + Clamp

Support

Valve + Coupler

Cautions + Others

Auto Backup Pin

WDC

High-Power Pneumatic Work Support

WNC

Pneumatic Work Support Rodless Hollow

WNA

Manifold Block/Nut

DZ-R

DZ-C

LZ-S

WNZ-SQ

● Cautions

● Notes on Handling

- 1) It should be operated by qualified personnel.
 - The hydraulic machine and air compressor should be operated and maintained by qualified personnel.
- 2) Do not operate or remove the product unless the safety protocols are ensured.
 - ① The machine and equipment can only be inspected or prepared when it is confirmed that the safety devices are in place.
 - ② Before the product is removed, make sure that the above-mentioned safety devices are in place. Shut off the pressure and power source, and make sure no pressure exists in the air and hydraulic circuits.
 - ③ After stopping the product, do not remove until the temperature drops.
 - ④ Make sure there is no trouble/issue in the bolts and respective parts before restarting the machine or equipment.
- 3) Do not touch a clamp (cylinder) while it is working. Otherwise, your hands may be injured.

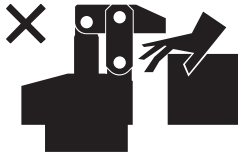

- 4) Do not disassemble or modify.
 - If the equipment is taken apart or modified, the warranty will be voided even within the warranty period.

● Maintenance and Inspection

- 1) Removal of the Machine and Shut-off of Pressure Source
 - Before removing the product, make sure that the safety devices are in place. Shut off the pressure and power source and make sure no pressure exists in the air and hydraulic circuits.
 - Make sure there is no trouble/issue in the bolts and respective parts before restarting.
- 2) Regularly clean the area around the piston rod and plunger.
 - If it is used when the surface is contaminated with dirt, it may lead to packing seal damage, malfunctioning, fluid leakage.

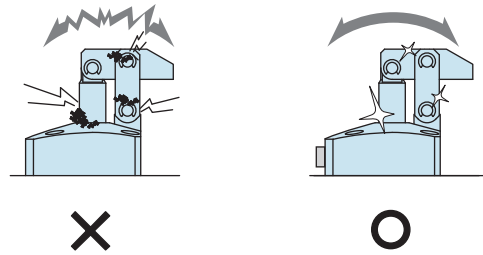

- 3) Regularly clean the reference surfaces (taper reference surface and seating surface) of locating products (SWT/SWQ/SWP/VRA/VRC/VX/VXE/VXF/WVS/VWH/VWM/VWK).
 - Locating products (except VRA/VRC/VX/VXE/VXF and SWR without air blow port) can remove contaminants with the cleaning function. When installing a workpiece or a pallet, make sure there are no contaminants such as thick sludge.
 - Continuous use with dirt on components will lead to locating failure, fluid leakage and malfunction.

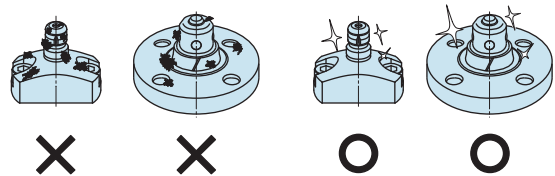

- 4) Regularly tighten pipe, mounting bolt, nut, snap ring, cylinder and others to ensure proper use.
- 5) Make sure the hydraulic fluid has not deteriorated.
- 6) Make sure there is a smooth action without an irregular noise.
 - Especially when it is restarted after left unused for a long period, make sure it can be operated correctly.
- 7) The products should be stored in the cool and dark place without direct sunshine or moisture.
- 8) Please contact us for overhaul and repair.

[Locating
+
Clamp](#)
[Locating](#)
[Hand · Clamp](#)
[Support](#)
[Valve · Coupler](#)
[Cautions · Others](#)
Cautions
[Installation Notes](#)
[Maintenance/
Inspection](#)
[Warranty](#)
[Company Profile](#)
[Company Profile](#)
[Our Products](#)
[History](#)
[Index](#)
[Search by
Alphabetical Order](#)
[Sales Offices](#)

● Warranty

1) Warranty Period

- The product warranty period is 18 months from shipment from our factory or 12 months from initial use, whichever is earlier.

2) Warranty Scope

- If the product is damaged or malfunctions during the warranty period due to faulty design, materials or workmanship, we will replace or repair the defective part at our expense.

Defects or failures caused by the following are not covered.

- ① If the stipulated maintenance and inspection are not carried out.
- ② Failure caused by the use of the non-confirming state at the user's discretion.
- ③ If it is used or operated in an inappropriate way by the operator. (Including damage caused by the misconduct of the third party.)
- ④ If the defect is caused by reasons other than our responsibility.
- ⑤ If repair or modifications are carried out by anyone other than Kosmek, or without our approval and confirmation, it will void warranty.
- ⑥ Other caused by natural disasters or calamities not attributable to our company.
- ⑦ Parts or replacement expenses due to parts consumption and deterioration. (Such as rubber, plastic, seal material and some electric components.)

Damages excluding from direct result of a product defect shall be excluded from the warranty.



WAHLTEC GmbH
 T: +49 (7584) 9238883
 F: +49 (7584) 9238887
 kosmek@wahltec.de
 www.wahltec.de

Sales Offices

Sales Offices across the World

JAPAN HEAD OFFICE Overseas Sales	TEL. +81-78-991-5162	FAX. +81-78-991-8787
	KOSMEK LTD. 1-5, 2-chome, Murotani, Nishi-ku, Kobe-city, Hyogo, Japan 651-2241 〒651-2241 兵庫県神戸市西区室谷2丁目1番5号	
United States of America SUBSIDIARY KOSMEK (USA) LTD.	TEL. +1-630-620-7650	FAX. +1-630-620-9015
	650 Springer Drive, Lombard, IL 60148 USA	
MEXICO REPRESENTATIVE OFFICE KOSMEK USA Mexico Office	TEL. +52-442-161-2347	
	Av. Santa Fe #103 int 59 Col. Santa Fe Juriquilla C.P. 76230 Queretaro, Qro Mexico	
EUROPE SUBSIDIARY KOSMEK EUROPE GmbH	TEL. +43-463-287587	FAX. +43-463-287587-20
	Schleppeplatz 2 9020 Klagenfurt am Wörthersee Austria	
CHINA KOSMEK (CHINA) LTD. 考世美(上海)貿易有限公司	TEL. +86-21-54253000	FAX. +86-21-54253709
	Room601, RIVERSIDE PYRAMID No.55, Lane21, Pusan Rd, Pudong Shanghai 200125, China 中国上海市浦东新区浦三路21弄55号银亿滨江中心601室 200125	
INDIA BRANCH OFFICE KOSMEK LTD - INDIA	TEL. +91-9880561695	
	F 203, Level-2, First Floor, Prestige Center Point, Cunningham Road, Bangalore -560052 India	
THAILAND REPRESENTATIVE OFFICE KOSMEK Thailand Representation Office	TEL. +66-2-300-5132	FAX. +66-2-300-5133
	67 Soi 58, RAMA 9 Rd., Suanluang, Suanluang, Bangkok 10250, Thailand	
TAIWAN (Taiwan Exclusive Distributor) Full Life Trading Co., Ltd. 盈生貿易有限公司	TEL. +886-2-82261860	FAX. +886-2-82261890
	16F-4, No.2, Jian Ba Rd., Zhonghe District, New Taipei City Taiwan 23511 台湾新北市中和區建八路2號 16F-4 (遠東世紀廣場)	
PHILIPPINES (Philippines Exclusive Distributor) G.E.T. Inc, Phil.	TEL. +63-2-310-7286	FAX. +63-2-310-7286
	Victoria Wave Special Economic Zone Mt. Apo Building, Brgy. 186, North Caloocan City, Metro Manila, Philippines 1427	
INDONESIA (Indonesia Exclusive Distributor) PT. Yamata Machinery	TEL. +62-21-29628607	FAX. +62-21-29628608
	Delta Commercial Park I, Jl. Kenari Raya B-08, Desa Jayamukti, Kec. Cikarang Pusat Kab. Bekasi 17530 Indonesia	

Sales Offices in Japan

Head Office Osaka Sales Office Overseas Sales	TEL. 078-991-5162	FAX. 078-991-8787
	〒651-2241 兵庫県神戸市西区室谷2丁目1番5号	
Tokyo Sales Office	TEL. 048-652-8839	FAX. 048-652-8828
	〒331-0815 埼玉県さいたま市北区大成町4丁目81番地	
Nagoya Sales Office	TEL. 0566-74-8778	FAX. 0566-74-8808
	〒446-0076 愛知県安城市美園町2丁目10番地1	
Fukuoka Sales Office	TEL. 092-433-0424	FAX. 092-433-0426
	〒812-0006 福岡県福岡市博多区上牟田1丁目8-10-101	

Global Network

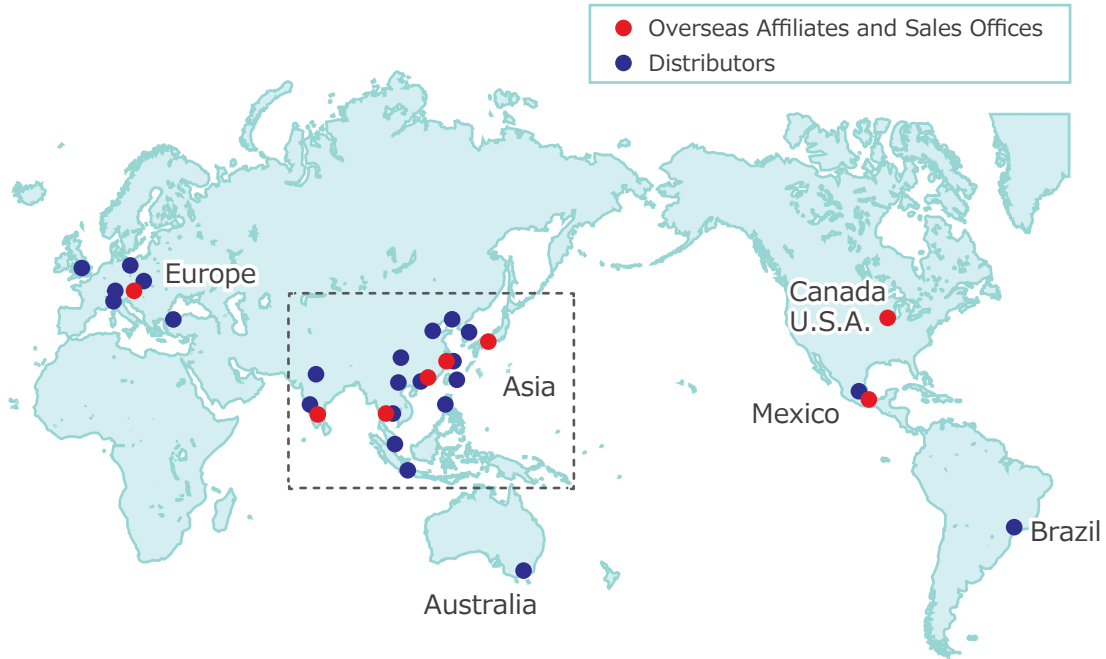

Asia Detailed Map



WAHLTEC GmbH
 T: +49 (7584) 9238883
 F: +49 (7584) 9238887
 kosmek@wahltec.de
 www.wahltec.de



● FOR FURTHER INFORMATION ON UNLISTED SPECIFICATIONS AND SIZES, PLEASE CALL US.
 ● SPECIFICATIONS IN THIS CATALOG ARE SUBJECT TO CHANGE WITHOUT NOTICE.

