

New

Air Clamp System Q Series

Kosmek Pneumatic Power Cylinder allows
Size Reduction with Built-in Mechanical Lock

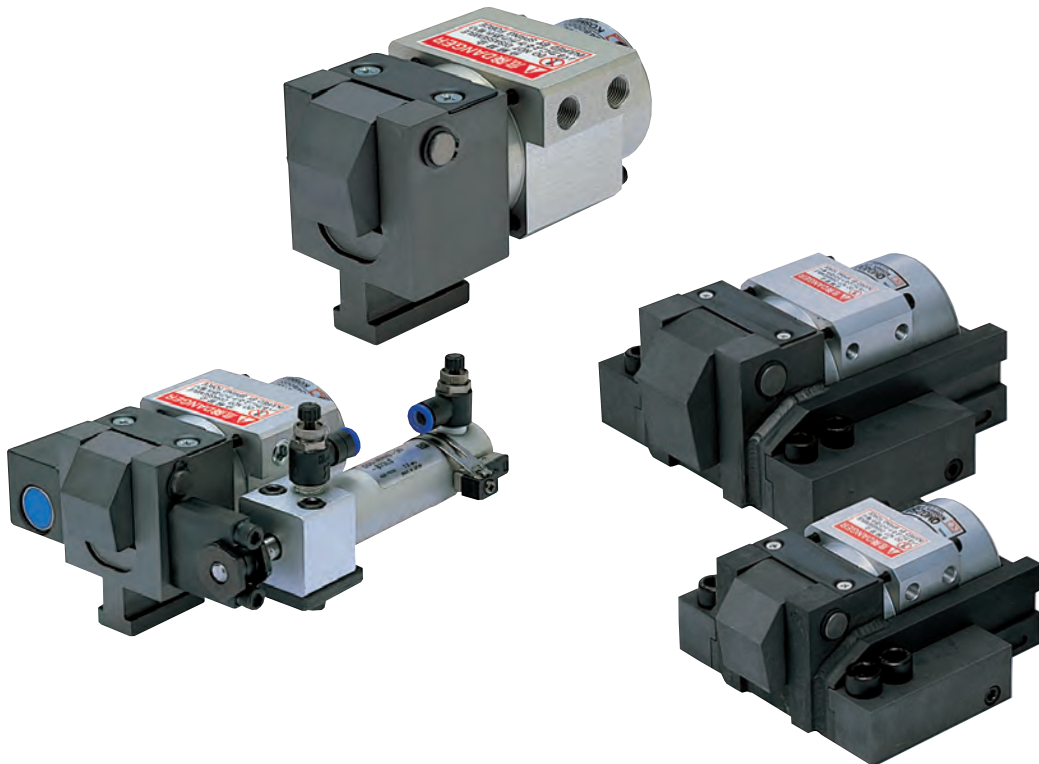

Features

Pneumatically driven mold clamp of which size reduction is realized by using a power cylinder having a newly developed built-in booster.

- Power source is general compressed air only.
- Air clamp system eliminates the possibility of contamination around the clamp due to oil leakage or dripping.
- Piping work is easy because the circuit consists of air lines.
- Fire hazard by use or storage of hydraulic oil is eliminated.
- Excellent for electric machines, no hydraulic source is required.
- Maintenance is easy as there is no oil mess.
- Endurance at high temperature is improved because the working pressure of this system is lower than that of the hydraulic model.
- The clamps satisfy the minimum mold thickness of almost all molding machines because of their compact design.
- They are most suitable for small size motor operated molding machines for producing semiconductors, food and medical components because of pneumatic drive.

Action Description

Released State

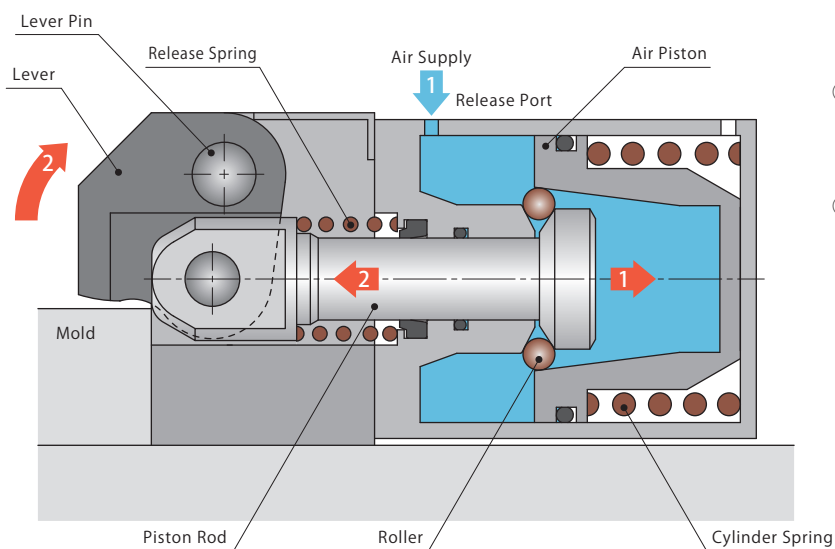

- ① By supplying 0.3 MPa air pressure to the release port, the piston rod moves backward compressing the cylinder spring.
- ② The piston rod is moved forward with air pressure and release spring force, and the lever rotates around the lever pin.

Locked State

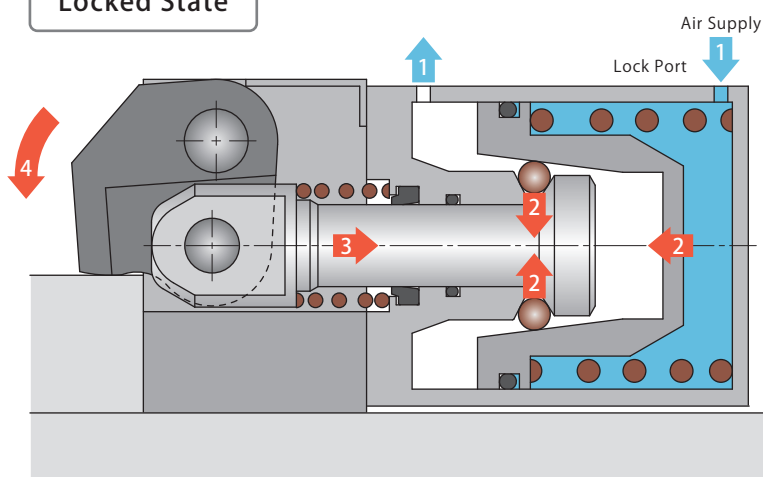

- ① Release air pressure through the release port and supply air pressure through the lock port.
- ② The air pressure and the cylinder spring force move the air piston forward to push the roller in contact with the taper surface of the air piston toward the center of the piston rod.
- ③ The force is increased by the booster to move the clamp rod backward.
- ④ The backward movement of the piston rod provides the lever with torque around the lever pin to lock the mold securely. (Lock Completed)

Layout : Vertical Loading Mold Change System

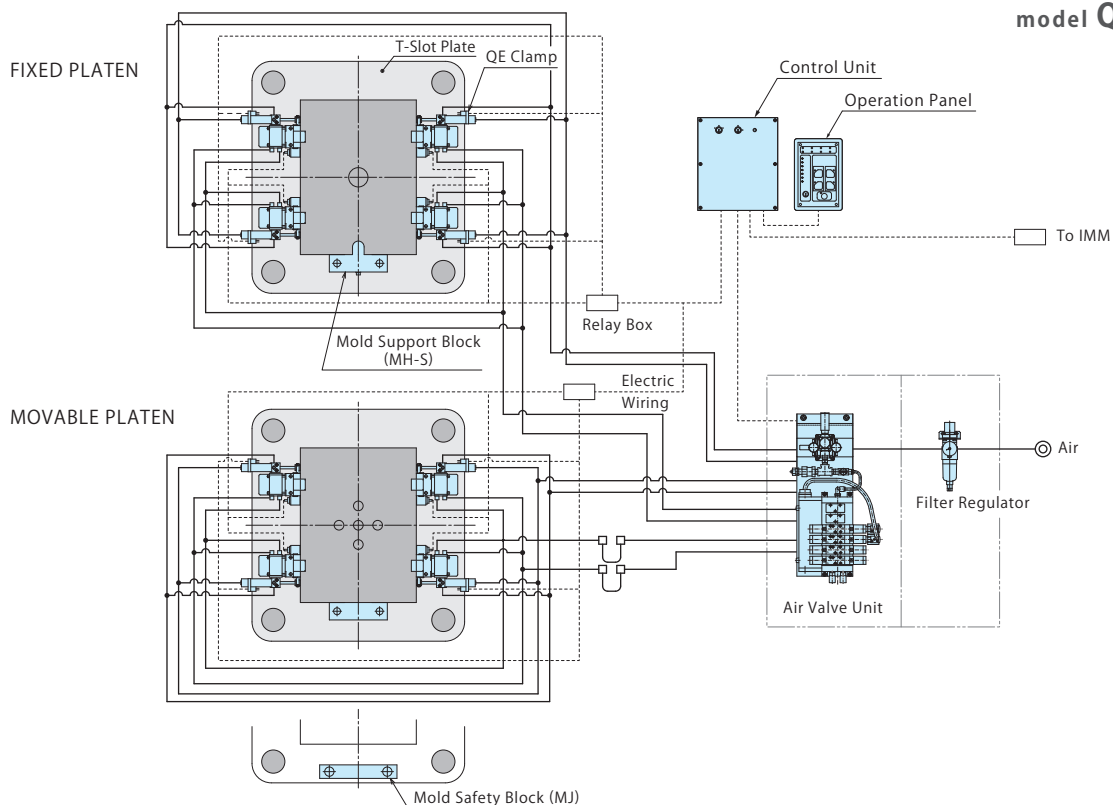

model QE

- Air Clamp System
- Air Clamp
- Air Valve Unit
- Operation Panel
- Control Unit
- Cautions

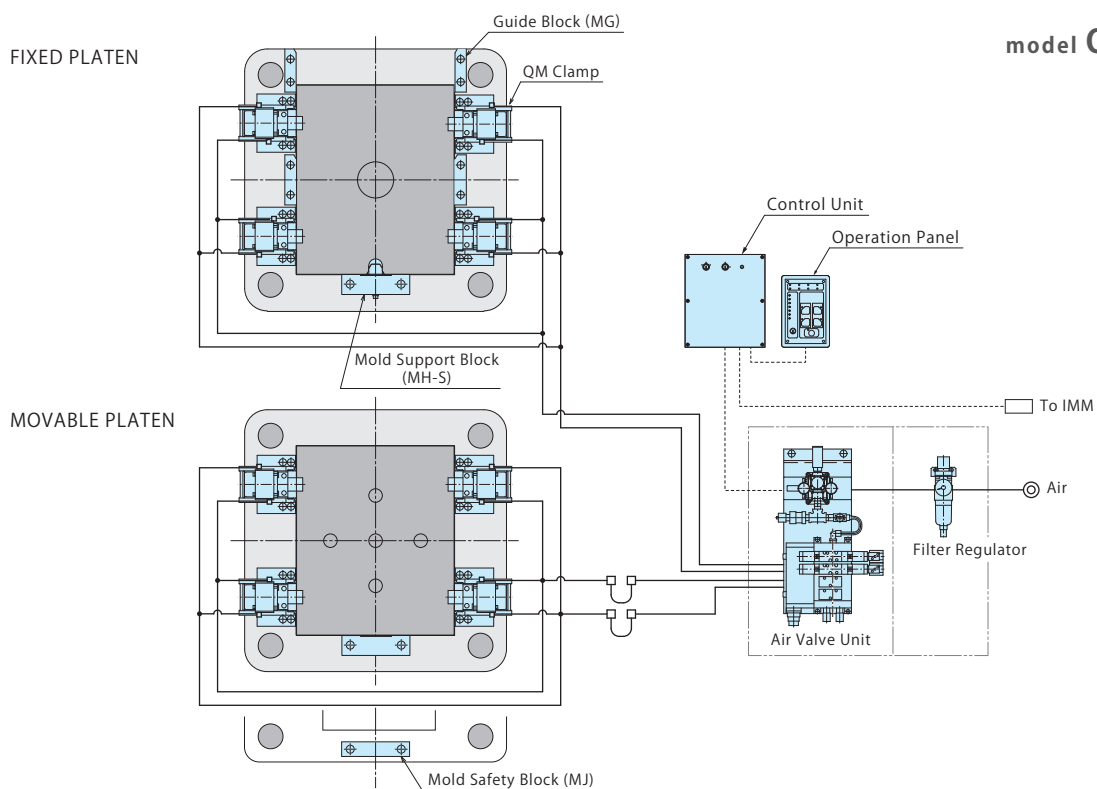

model QM

Standard System (QB / QE / QM / QR)

※1. Specification in the bracket is for QE / QR.

IMM Capacity (kN)	Clamp						Valve ^{※1} Unit	Mold Support Block	Mold Holding Block	Guide Block
	QB Clamp	QE Clamp	QM Clamp	QR Clamp	Qty.	STA. / MOV. Clamping Force (kN)				
~ 500	QB0100	QE0100	QM0100	QR0100	8	40	MV9012-UU-5 (MV9012-UUSS-5)	MH03	MJ0010	MG
~ 750	QB0160	QE0160	QM0160	QR0160	8	64				
~ 1500	QB0250	QE0250	QM0250	QR0250	8	100		MH04	MJ0020	
~ 2500	QB0400	QE0400	QM0400	QR0400	8	160				
~ 3500	QB0630	QE0630	QM0630	QR0630	8	252				

Note : 1. Please contact us for layout drawing of model QB / QR.

Model No. Indication

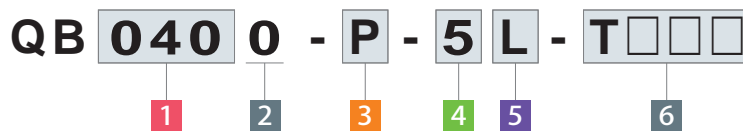

1 Clamping Capacity

010	: 10kN
016	: 16kN
025	: 25kN
040	: 40kN
063	: 63kN

2 Design No.

0 : Revision Number

3 Option ^{※1}

Blank	: Standard
H	: Extra Height (When h dimension is more than max. h in the external drawing.)
J	: Low Lever (When h dimension is less than min. h in the external drawing.)
P	: With Mold Confirmation Proximity Switch ^{※2}
V	: High Temperature (0~120°C)

Notes :

- ※1. Please contact us for specifications and dimensions other than **Blank** : standard.
- ※2. Please indicate **4** Proximity Switch Load Voltage (Current) and **5** Proximity Switch Mounting Position for **P** : Mold Confirmation Proximity Switch.
 1. Please contact us for a combination of options.

4 Proximity Switch Load Voltage (Current) Only when **3** Option **P** : With Mold Confirmation Proximity Switch is chosen.

1	: AC100V
2	: AC200V
5	: DC24V (5~40mA)

5 Proximity Switch Mounting Position Only when **3** Option **P** : With Mold Confirmation Proximity Switch is chosen.

L	: Left (Left Side as Seen from Clamp Back Side)
R	: Right (Right Side as Seen from Clamp Back Side)

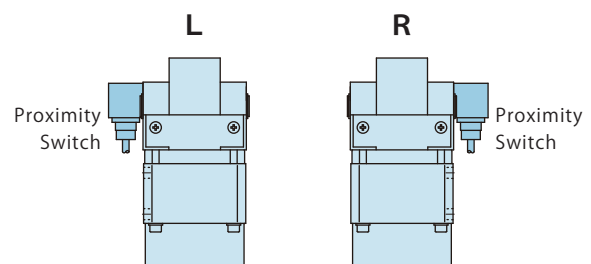

6 Production Number

This number represents the main specification of the clamp's T-slot stem and the clamping height. After the specification is confirmed, we will create a number.

Specifications : Clamp Body

Model No.		QB0100	QB0160	QB0250	QB0400	QB0630
Clamping Capacity ^{※3}	kN	10	16	25	40	63
Residual Clamping Force ^{※4}	kN	1.6	2.6	4	6.5	10
Holding Force ^{※5}	Air Pressure 0.4	10	16	25	40	63
	Air Pressure 0	3.5	6	9	14.5	22
Clamping Force ^{※5}	Air Pressure 0.8	2.9	4.5	7	11.5	17
	Air Pressure 0.4	1.6	2.6	4	6.5	10
	Air Pressure 0	0.4	0.6	1	1.5	2.3
Full Stroke	mm	2.6	2.8	3.4	4.3	4.6
Clamp Stroke	mm	0.6	0.6	0.6	0.6	0.8
Extra Stroke	mm	2	2.2	2.8	3.7	3.8
Cylinder Capacity ^{cm³}	Lock	23	42	77	162	265
	Release	21	38	71	150	244
Operating Air Pressure (Recommended)	MPa	0.4 ~ 0.8				
Max. Operating Air Pressure	MPa	1.0				
Min. Operating Air Pressure ^{※6}	MPa	0.3				
Usable Fluid		Dry Air				
Operating Temperature ^{※7}	°C	0~70 (V : High temperature type is available for 0~120°C)				
Use Frequency ^{※8}		Max. 20 Cycles / Day				
Min. T-slot Width a (JIS) ^{※9}	mm	10	12	14	18	22
Max. T-slot Width a (JIS) ^{※9}	mm	20	24	32	42	42

Notes :

- ※3. Do not exceed the clamp's capacity.
- ※4. Residual clamping force means the clamping force when air pressure drops to 0MPa from clamped state with 0.4MPa air pressure.
- ※5. There is ±10% variation in holding force and clamping force.
- ※6. To maintain the released state, supply 0.3MPa or more in air pressure to the release port.
- ※7. Option **V** : High Temperature for operating temperature 0~120°C.
- ※8. Please contact us for more frequent use.
- ※9. The minimum and maximum T-slot widths are reference.
 1. The accuracy of the mold clamping thickness (h dimension) should be better than ±0.2mm for QB0100/QB0160/QB0250 and ±0.3mm for QB0400/QB0630.

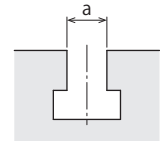

Performance Curve

Holding Force Curve

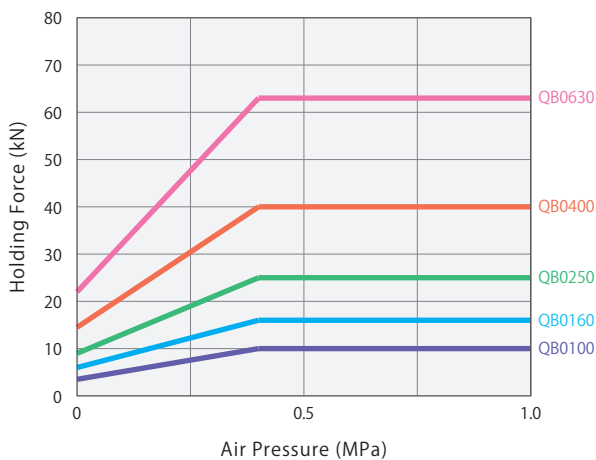

Clamping Force Curve

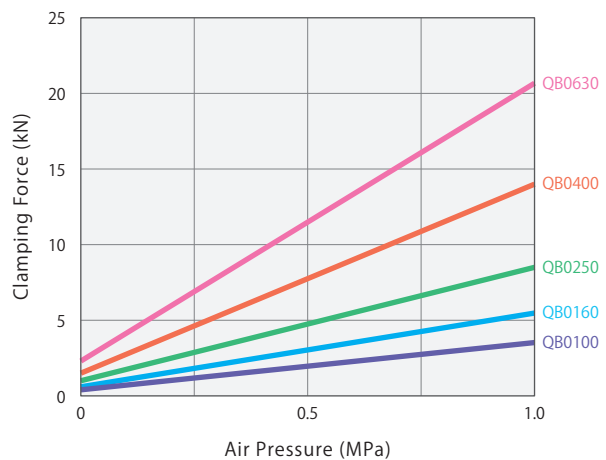

External Dimensions

※ This drawing shows the standard model of QB0100 / QB0160 / QB0250. Contact us for external dimensions for options.

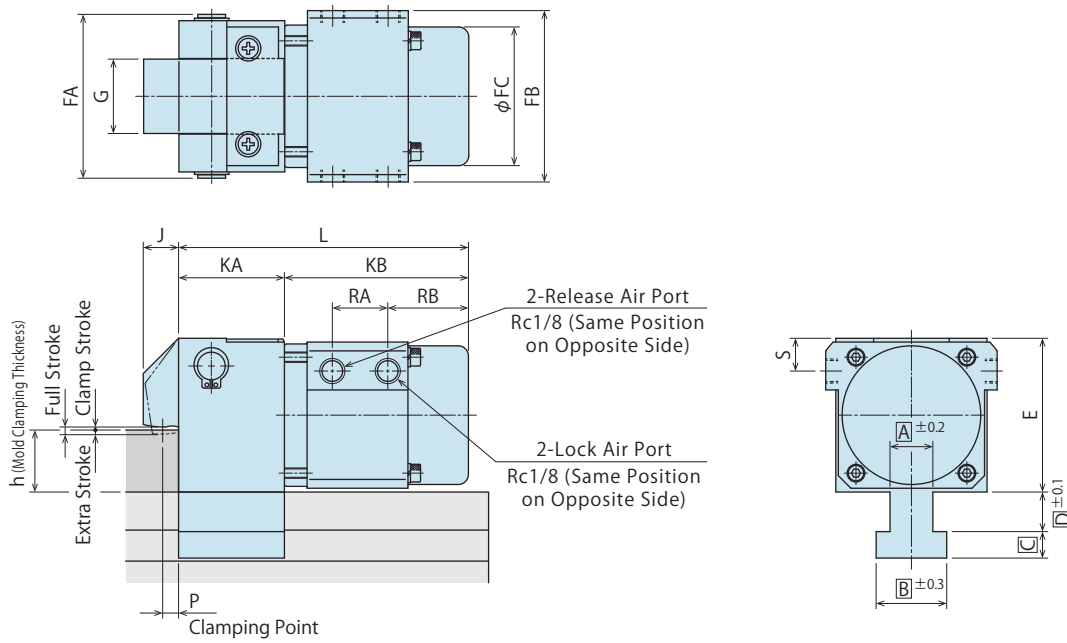

※ This drawing shows the standard model of QB0400 / QB0630. Contact us for external dimensions for options.

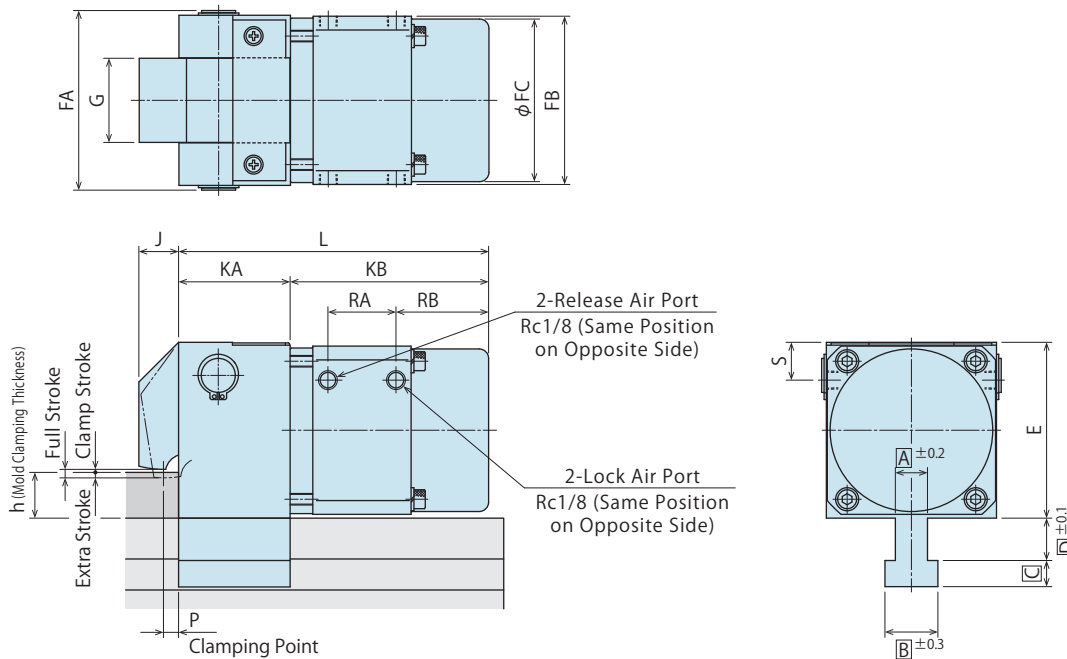

Notes :

1. Do not exceed the clamp's capacity.
2. Specifications/Contents in this catalog are subject to change without prior notice. Ask for the approval drawing before deciding to purchase.

T-Slot Dimensions

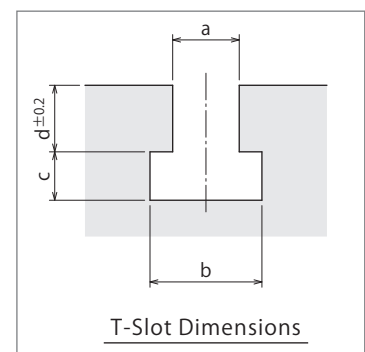

External Dimensions

(mm)

Model No.		QB0100	QB0160	QB0250	QB0400	QB0630
Full Stroke		2.6	2.8	3.4	4.3	4.6
Clamp Stroke		0.6	0.6	0.6	0.6	0.8
Extra Stroke		2	2.2	2.8	3.7	3.8
min. E		51	61	73	93	115.5
FA		55	65	77	95	117
FB		62	68	73	89	110
FC		45.5	55	67	86	108
G		24.5	29.5	35.5	44.5	55.5
J		12	14	16	21	24
KA		38	42	49	59	71
KB		66	73	85	105	121
L		104	115	134	164	192
P		6	6.5	7	8	9
RA		21	22	25	36	42
RB		27	32	42	49	57
S		11	13	15.5	20	24.5
Mold Clamping Thickness	min. h	15 \pm 0.2	15 \pm 0.2	20 \pm 0.2	25 \pm 0.3	30 \pm 0.3
	max. h	30 \pm 0.2	35 \pm 0.2	40 \pm 0.2	50 \pm 0.3	60 \pm 0.3

Notes :

1. A B C D dimensions are determined by Kosmek according to the T-slot dimensions.
2. When making an order, please indicate a, b, c, d dimensions of T-slot and h dimensions of mold clamping thickness in 0.1mm increments.
3. Tolerance of dimension d of T-slot should be better than ± 0.2 mm.
4. The accuracy of the mold clamping thickness (h dimension) should be better than ± 0.2 mm for QB0100/QB0160/QB0250 and ± 0.3 mm for QB0400/QB0630.
5. Please contact us for unlisted specifications and dimensions.

Model No. Indication

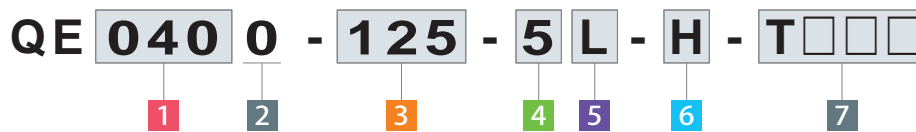

1 Clamping Capacity

010	: 10kN
016	: 16kN
025	: 25kN
040	: 40kN
063	: 63kN

2 Design No.

0 : Revision Number

3 Slide Stroke (Air Cylinder Stroke) ※1

25	: Clamp Travel Distance = 25mm
300	: Clamp Travel Distance = 300mm

Notes:

※1. Selectable 3 Slide Stroke Length differs according to 1 Clamping Force.

Please refer to the slide stroke on specifications.

1. Extra distance should be considered when determining the travel distance.

4 Switch Load Voltage (Current)

1	: AC100V
2	: AC200V
5	: DC24V (5~40mA)

5 Air Cylinder Mounting Position

L	: Left (Left Side as Seen from Clamp Back Side)
R	: Right (Right Side as Seen from Clamp Back Side)

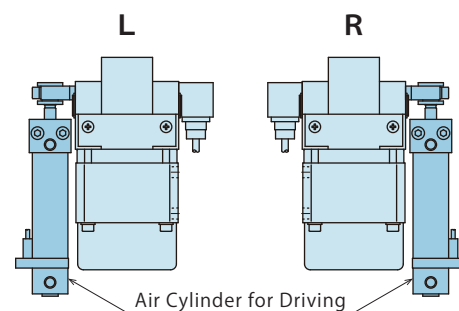

6 Option ※2

Blank	: Standard
H	: Extra Height (When h dimension is more than max. h in the external drawing.)
J	: Low Lever (When h dimension is less than min. h in the external drawing.)
Q	: Double Air Cylinder
S	: Special Spacer
V	: High Temperature (0~120°C)

Notes:

※2. Please contact us for specifications and dimensions other than **Blank**: standard.

2. Please contact us for a combination of options.

7 Production Number

This number represents the main specification of the clamp's T-slot stem and the clamping height. After the specification is confirmed, we will create a number.

Specifications : Clamp Body

Model No.		QE0100	QE0160	QE0250	QE0400	QE0630	
QB Clamp Model No.		QB0100	QB0160	QB0250	QB0400	QB0630	
Clamping Capacity ^{※3}	kN	10	16	25	40	63	
Residual Clamping Force ^{※4}	kN	1.6	2.6	4	6.5	10	
Holding Force ^{※5}	Air Pressure 0.4	MPa	10	16	25	40	63
	Air Pressure 0	MPa	3.5	6	9	14.5	22
Clamping Force ^{※5}	Air Pressure 0.8	MPa	2.9	4.5	7	11.5	17
	Air Pressure 0.4	MPa	1.6	2.6	4	6.5	10
	Air Pressure 0	MPa	0.4	0.6	1	1.5	2.3
Slide Stroke ^{※6}	mm	25 ~ 200	25 ~ 200	25 ~ 200	25 ~ 300	25 ~ 300	
Full Stroke	mm	2.6	2.8	3.4	4.3	4.6	
Clamp Stroke	mm	0.6	0.6	0.6	0.6	0.8	
Extra Stroke	mm	2	2.2	2.8	3.7	3.8	
Cylinder Capacity ^{cm³}	Lock		23	42	77	162	265
	Release		21	38	71	150	244
Operating Air Pressure (Recommended)	MPa	0.4 ~ 0.8					
Max. Operating Air Pressure	MPa	1.0					
Min. Operating Air Pressure ^{※7}	MPa	0.3					
Air Pressure for Air Cylinder	MPa	0.4 ~ 0.5					
Usable Fluid		Dry Air					
Operating Temperature ^{※8}	°C	0~70 (V : High temperature type is available for 0~120°C)					
Use Frequency ^{※9}		Max. 20 Cycles / Day					
Min. T-slot Width a (JIS) ^{※10}	mm	10	12	14	18	22	
Max. T-slot Width a (JIS) ^{※10}	mm	20	24	32	42	42	

Notes :

- ※3. Do not exceed the clamp's capacity.
- ※4. Residual clamping force means the clamping force when air pressure drops to 0MPa from clamped state with 0.4MPa air pressure.
- ※5. There is ±10% variation in holding force and clamping force.
- ※6. Dimensions **A** and **K** are different when exceeding the slide stroke value written in the list.
- ※7. To maintain the released state, supply 0.3MPa or more in air pressure to the release port.
- ※8. Option **V** : High Temperature for operating temperature 0~120°C.
- ※9. Please contact us for more frequent use.
- ※10. The minimum and maximum T-slot widths are reference.
 1. The accuracy of the mold clamping thickness (h dimension) should be better than ±0.2mm for QE0100/QE0160/QE0250 and ±0.3mm for QE0400/QE0630.

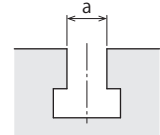

Performance Curve

Holding Force Curve

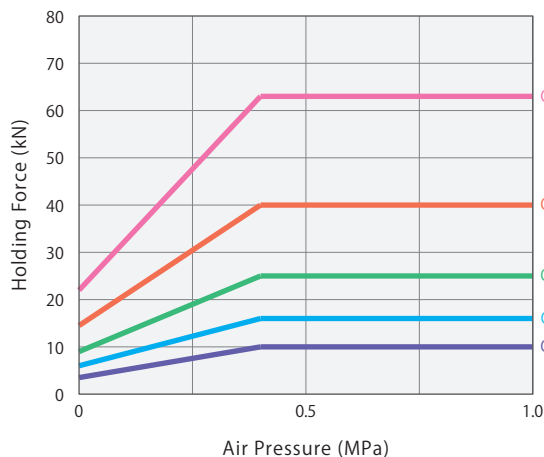

Clamping Force Curve

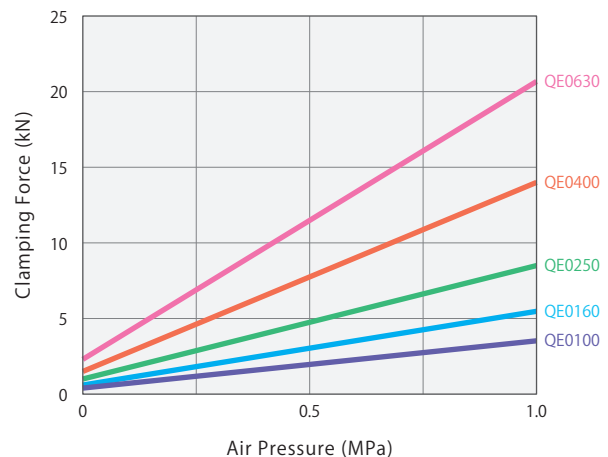

External Dimensions

※ This drawing shows the standard model of QE0100 ~ QE0630.
Please refer to QB Clamp pages for details of clamp body.

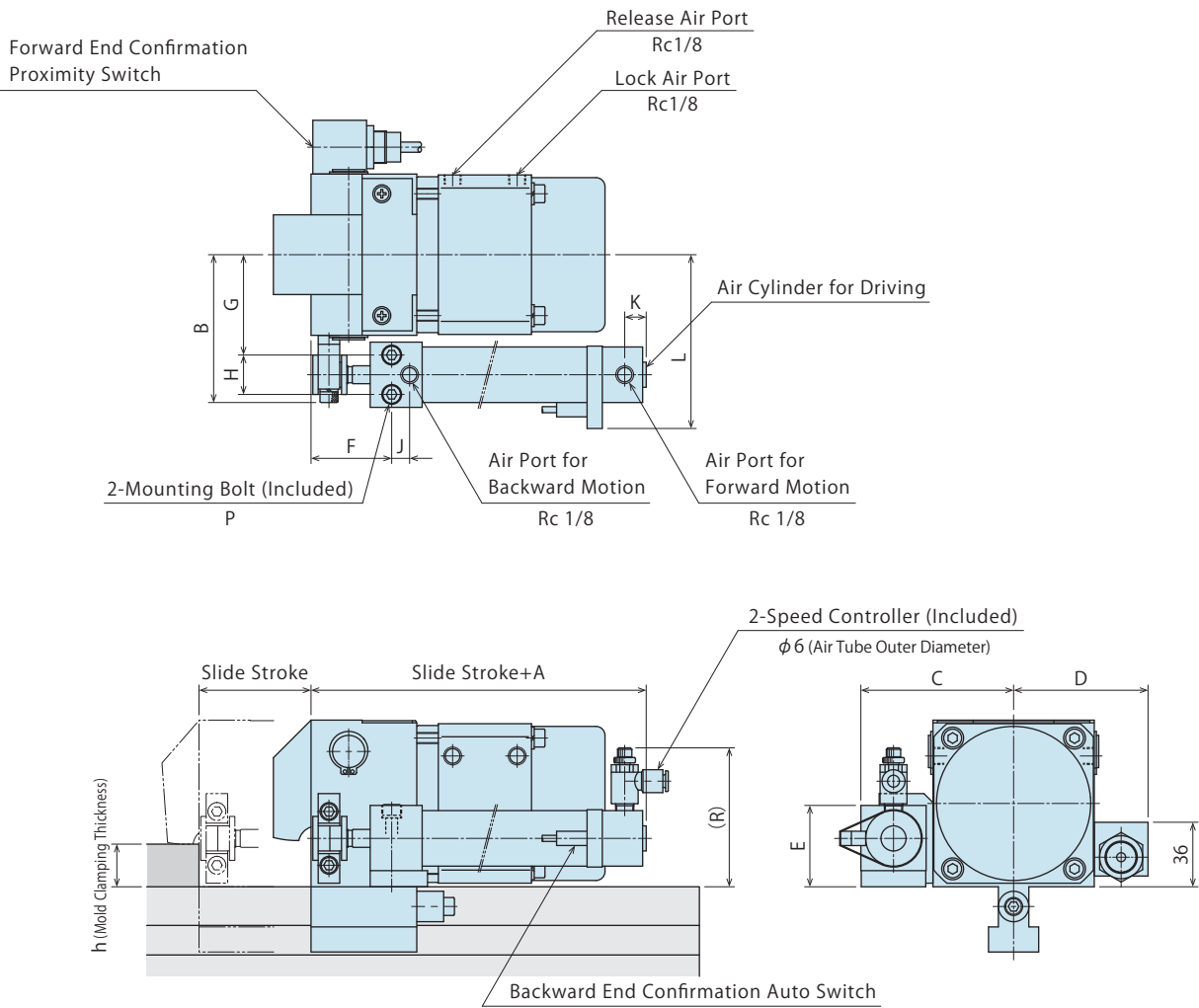

Notes :

1. Do not exceed the clamp's capacity.
2. Specifications/Contents in this catalog are subject to change without prior notice. Ask for the approval drawing before deciding to purchase.

T-Slot Dimensions

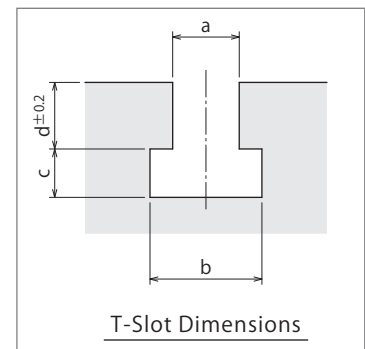

External Dimensions

(mm)

Model No.	QE0100	QE0160	QE0250	QE0400	QE0630	
QB Clamp Model No.	QB0100	QB0160	QB0250	QB0400	QB0630	
Full Stroke	2.6	2.8	3.4	4.3	4.6	
Clamp Stroke	0.6	0.6	0.6	0.6	0.8	
Extra Stroke	2	2.2	2.8	3.7	3.8	
A ※1	105 (113)	105 (113)	105 (113)	112 (120)	118 (126)	
B	62.5	61.5	67.5	82.5	100	
C	65.5	64.5	70.5	85.5	102	
D	55	60	66	75	86	
E	36.5	36.5	36.5	45.5	54.5	
F	39	39	39	45	46	
G	41	40	46	56	68.5	
H	18	18	18	22	24	
J	9	9	9	10	13	
K ※1	12 (14)	12 (14)	12 (14)	12 (14)	12 (14)	
L	77.5	76.5	82.5	97	114	
P	Mounting Bolt (Nominal × Pitch × Length)	M5×0.8×40	M5×0.8×40	M5×0.8×40	M6×1×50	M8×1.25×55
	Mounting Hole (Nominal × Pitch × Depth)	M5×0.8×10	M5×0.8×10	M5×0.8×10	M6×1×12	M8×1.25×16
R	66	66	66	74.5	84	
Mold Clamping Thickness	min. h	15±0.2	15±0.2	20±0.2	25±0.3	30±0.3
	max. h	30±0.2	35±0.2	40±0.2	50±0.3	60±0.3

Notes :

- ※1. Dimensions A and K in the bracket are the dimensions when exceeding the slide stroke written in the specifications.
 1. Please refer to QB clamp pages for unlisted dimensions.
 2. When making an order, please indicate a, b, c, d dimensions of T-slot and h dimensions of mold clamping thickness in 0.1mm increments.
 3. The accuracy of the mold clamping thickness (h dimension) should be better than ±0.2mm for QE0100/QE0160/QE0250, and ±0.3mm for QE0400/QE0630.

Specifications : Proximity Switch

Proximity Switch Model No.	FL7M-7J6HD-L5	FL7M-7T7HD-L5
Manufacturer	Azbil	Azbil
Voltage	DC10~30V	AC100V / AC200V
Internal Voltage Drop	3V or less	10V or less
Load Current	3~100mA	5~100mA

Specifications : Auto Switch

Auto Switch Model No.	D-A93L	
Manufacturer	SMC	
Voltage	DC24V	AC100V
Internal Voltage Drop	3V or less	2.4V or less
Load Current	5~40mA	5~20mA

● Model No. Indication

QM **040** **0** - **30** - **P** - **5**

1 2 3 4 5

1 Clamping Capacity

010 : 10kN
016 : 16kN
025 : 25kN
040 : 40kN
063 : 63kN

2 Design No.

0 : Revision Number

3 Mold Clamping Thickness

30 : Mold Clamping Thickness h=30mm
50 : Mold Clamping Thickness h=50mm

4 Option ^{※1}

Blank : Standard
B□ : With Spacer ^{※2}
P : With Mold Confirmation Proximity Switch
V : High Temperature (0~120°C)

Notes :

- ※1. Please contact us for specifications and dimensions other than **Blank** : standard.
- ※2. Indicate spacer thickness in 1mm increments in □ for **B□** : with Spacer.
- 1. Please contact us for a combination of options.

5 Proximity Switch Load Voltage (Current) Only when **4** Option **P** : With Mold Confirmation Proximity Switch is chosen.

1 : AC100V
2 : AC200V
5 : DC24V (5~40mA)

Specifications : Clamp Body

Model No.		QM0100	QM0160	QM0250	QM0400	QM0630
Clamping Capacity ^{※3}	kN	10	16	25	40	63
Residual Clamping Force ^{※4}	kN	1.6	2.6	4	6.5	10
Holding Force ^{※5}	Air Pressure 0.4 MPa	10	16	25	40	63
	Air Pressure 0 MPa	3.5	6	9	14.5	22
Clamping Force ^{※5}	Air Pressure 0.8 MPa	2.9	4.5	7	11.5	17
	Air Pressure 0.4 MPa	1.6	2.6	4	6.5	10
	Air Pressure 0 MPa	0.4	0.6	1	1.5	2.3
Actual Slide Stroke	mm	35	40	50	60	75
Full Stroke	mm	2.6	2.8	3.4	4.3	4.6
Clamp Stroke	mm	0.6	0.6	0.6	0.6	0.8
Extra Stroke	mm	2	2.2	2.8	3.7	3.8
Cylinder Capacity _{cm³}	Lock	23	42	77	162	265
	Release	21	38	71	150	244
Operating Air Pressure (Recommended)	MPa	0.4 ~ 0.8				
Max. Operating Air Pressure	MPa	1.0				
Min. Operating Air Pressure ^{※6}	MPa	0.3				
Usable Fluid		Dry Air				
Operating Temperature ^{※7}	°C	0~70 (V : High temperature type is available for 0~120°C)				
Use Frequency ^{※8}		Max. 20 Cycles / Day				

- Air Clamp System
- Air Clamp
- Air Valve Unit
- Operation Panel Control Unit
- Cautions

Notes :

- ※3. Do not exceed the clamp's capacity.
 - ※4. Residual clamping force means the clamping force when air pressure drops to 0MPa from clamped state with 0.4MPa air pressure.
 - ※5. There is ±10% variation in holding force and clamping force.
 - ※6. To maintain the released state, supply 0.3MPa or more in air pressure to the release port.
 - ※7. Option **V** : High Temperature for operating temperature 0~120°C.
 - ※8. Please contact us for more frequent use.
1. The accuracy of the mold clamping thickness (h dimension) should be better than ±0.3mm.

Performance Curve

Holding Force Curve

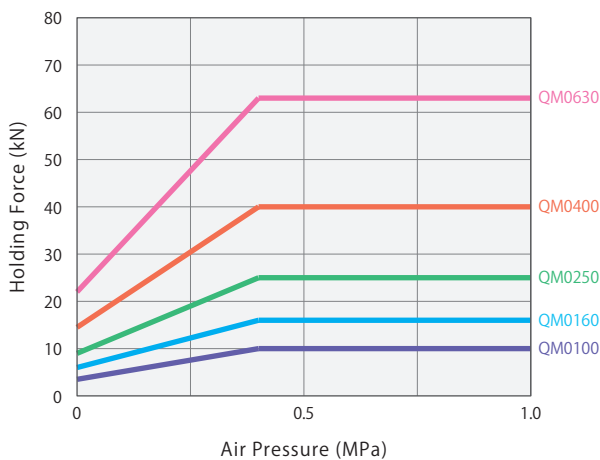

Clamping Force Curve

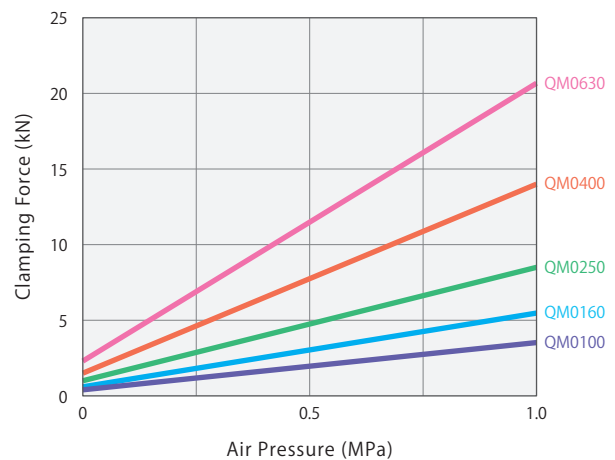

External Dimensions

※ This drawing shows the standard model of QM0100 ~ QM0630.
 Contact us for external dimensions for options.

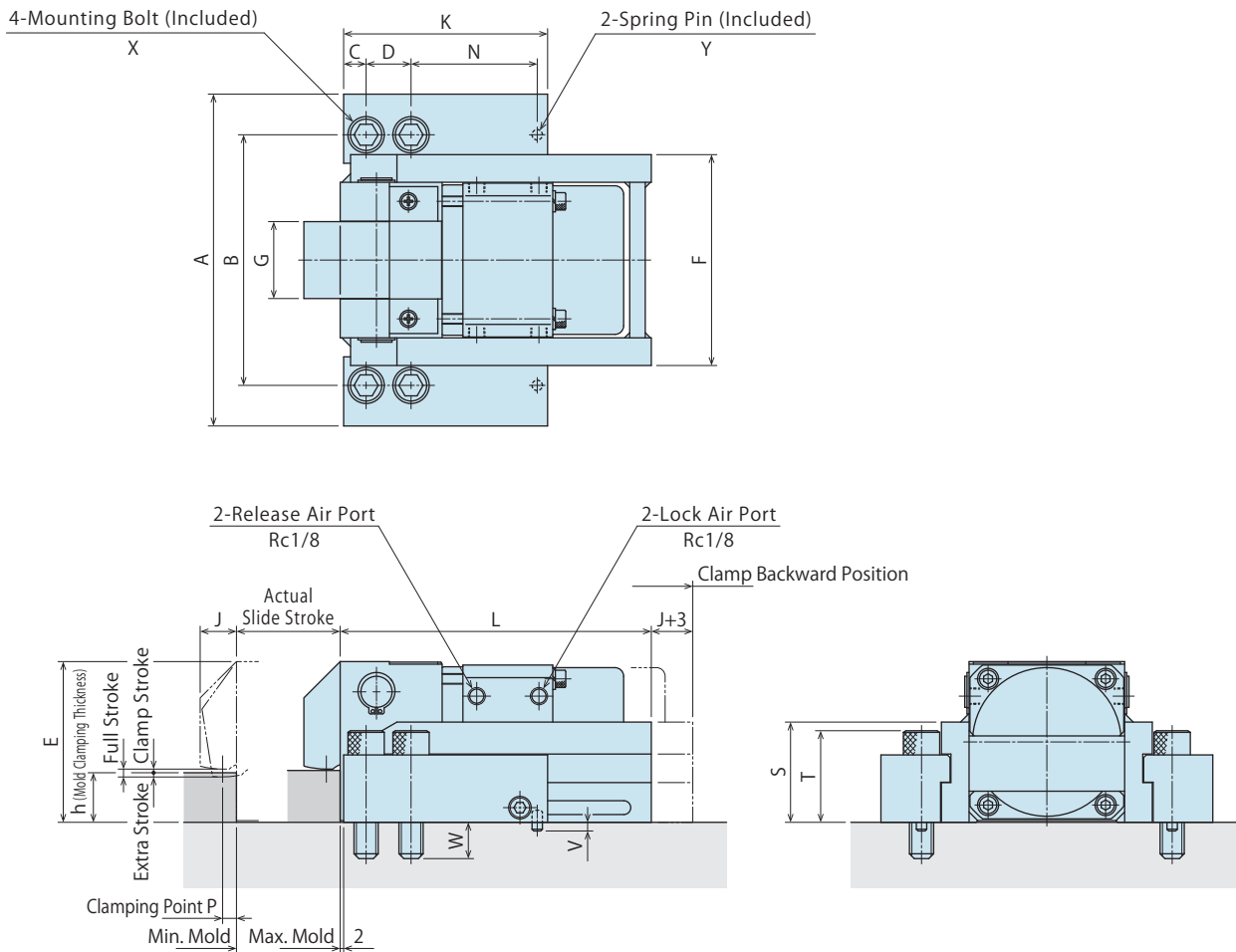

External Dimensions

(mm)

Model No.	QM0100	QM0160	QM0250	QM0400	QM0630	
Full Stroke	2.6	2.8	3.4	4.3	4.6	
Clamp Stroke	0.6	0.6	0.6	0.6	0.8	
Extra Stroke	2	2.2	2.8	3.7	3.8	
A	106	129	152	192	243	
B	83	98	116	145	190	
C	8.5	10	12	13	18	
D	15	18	20	26	36	
E	51	61	73	93	115.5	
F	68	80	96	122	156	
G	24.5	29.5	35.5	44.5	55.5	
J	12	14	16	21	24	
K	77	85	94	118	136	
L	114	127	146	180	213	
N	49.5	53	57	73	72	
P	6	6.5	7	8	9	
S	30.5	38.5	48	58	72	
T	28.5	35	43.5	53	68.5	
V	3	3	4	5	8	
W	14.5	15	18.5	21	31.5	
X (Nominal × Pitch × Length)	M8×1.25×35	M10×1.5×40	M12×1.75×50	M14×2×60	M20×2.5×80	
Y	φ4×8	φ4×8	φ5×10	φ6×12	φ8×16	
Mold Clamping Thickness	min. h	15±0.3	15±0.3	20±0.3	25±0.3	30±0.3
	max. h	30±0.3	35±0.3	40±0.3	50±0.3	60±0.3

Notes :

1. The accuracy of the mold clamping thickness (h dimension) should be better than ±0.3mm.
2. Dimension K should be within the platen when mounting a clamp.

Air Clamp System
Air Clamp
Air Valve Unit
Operation Panel Control Unit
Cautions

● Model No. Indication

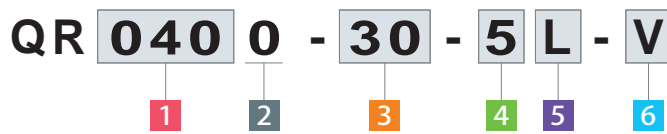

1 Clamping Capacity

010	: 10kN
016	: 16kN
025	: 25kN
040	: 40kN
063	: 63kN

2 Design No.

0 : Revision Number

3 Mold Clamping Thickness

30	: Mold Clamping Thickness	h=30mm
50	: Mold Clamping Thickness	h=50mm

4 Switch Load Voltage (Current)

5 : DC24V (5~40mA)

5 Air Cylinder Mounting Position

L : Left (Left Side as Seen from Clamp Back Side)
R : Right (Right Side as Seen from Clamp Back Side)

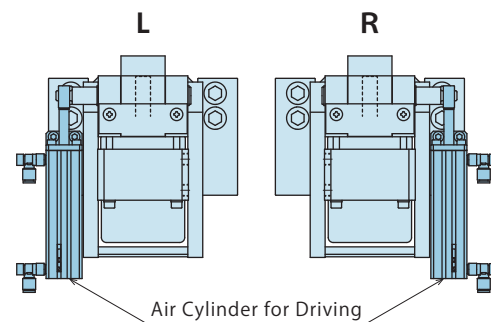

6 Option

Blank : Standard
V : High Temperature (0~120°C)

Specifications : Clamp Body

Model No.		QR0100	QR0160	QR0250	QR0400	QR0630
QM Clamp Model No.		QM0100	QM0160	QM0250	QM0400	QM0630
Clamping Capacity ^{※1}	kN	10	16	25	40	63
Residual Clamping Force ^{※2}	kN	1.6	2.6	4	6.5	10
Holding Force ^{※3}	Air Pressure 0.4 MPa	10	16	25	40	63
	Air Pressure 0 MPa	3.5	6	9	14.5	22
Clamping Force ^{※3}	Air Pressure 0.8 MPa	2.9	4.5	7	11.5	17
	Air Pressure 0.4 MPa	1.6	2.6	4	6.5	10
	Air Pressure 0 MPa	0.4	0.6	1	1.5	2.3
Actual Slide Stroke	mm	35	40	50	60	75
Full Stroke	mm	2.6	2.8	3.4	4.3	4.6
Clamp Stroke	mm	0.6	0.6	0.6	0.6	0.8
Extra Stroke	mm	2	2.2	2.8	3.7	3.8
Cylinder Capacity _{cm³}	Lock	23	42	77	162	265
	Release	21	38	71	150	244
Operating Air Pressure (Recommended)	MPa	0.4 ~ 0.8				
Max. Operating Air Pressure	MPa	1.0				
Min. Operating Air Pressure ^{※4}	MPa	0.3				
Air Pressure for Air Cylinder	MPa	0.4 ~ 0.5				
Usable Fluid		Dry Air				
Operating Temperature ^{※5}	°C	0~70 (V : High temperature type is available for 0~120°C)				
Use Frequency ^{※6}		Max. 20 Cycles / Day				

Notes :

- ※1. Do not exceed the clamp's capacity.
- ※2. Residual clamping force means the clamping force when air pressure drops to 0MPa from clamped state with 0.4MPa air pressure.
- ※3. There is ±10% variation in holding force and clamping force.
- ※4. To maintain the released state, supply 0.3MPa or more in air pressure to the release port.
- ※5. Option **V** : High Temperature for operating temperature 0~120°C.
- ※6. Please contact us for more frequent use.
 1. The accuracy of the mold clamping thickness (h dimension) should be better than ±0.3mm.

Performance Curve

Holding Force Curve

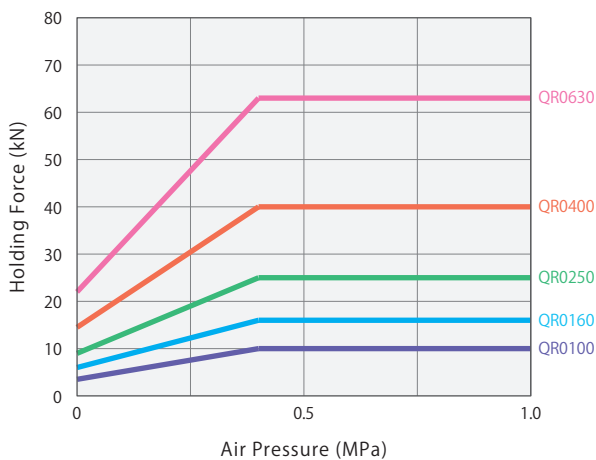

Clamping Force Curve

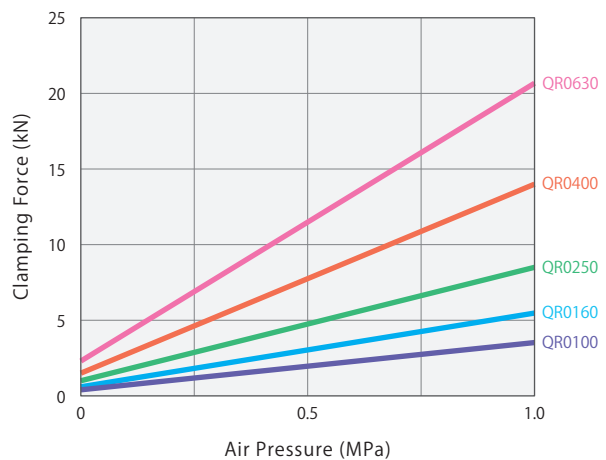

External Dimensions

※ This drawing shows the standard model of QR0100 ~ QR0630.
Please refer to QM Clamp pages for details of clamp body.

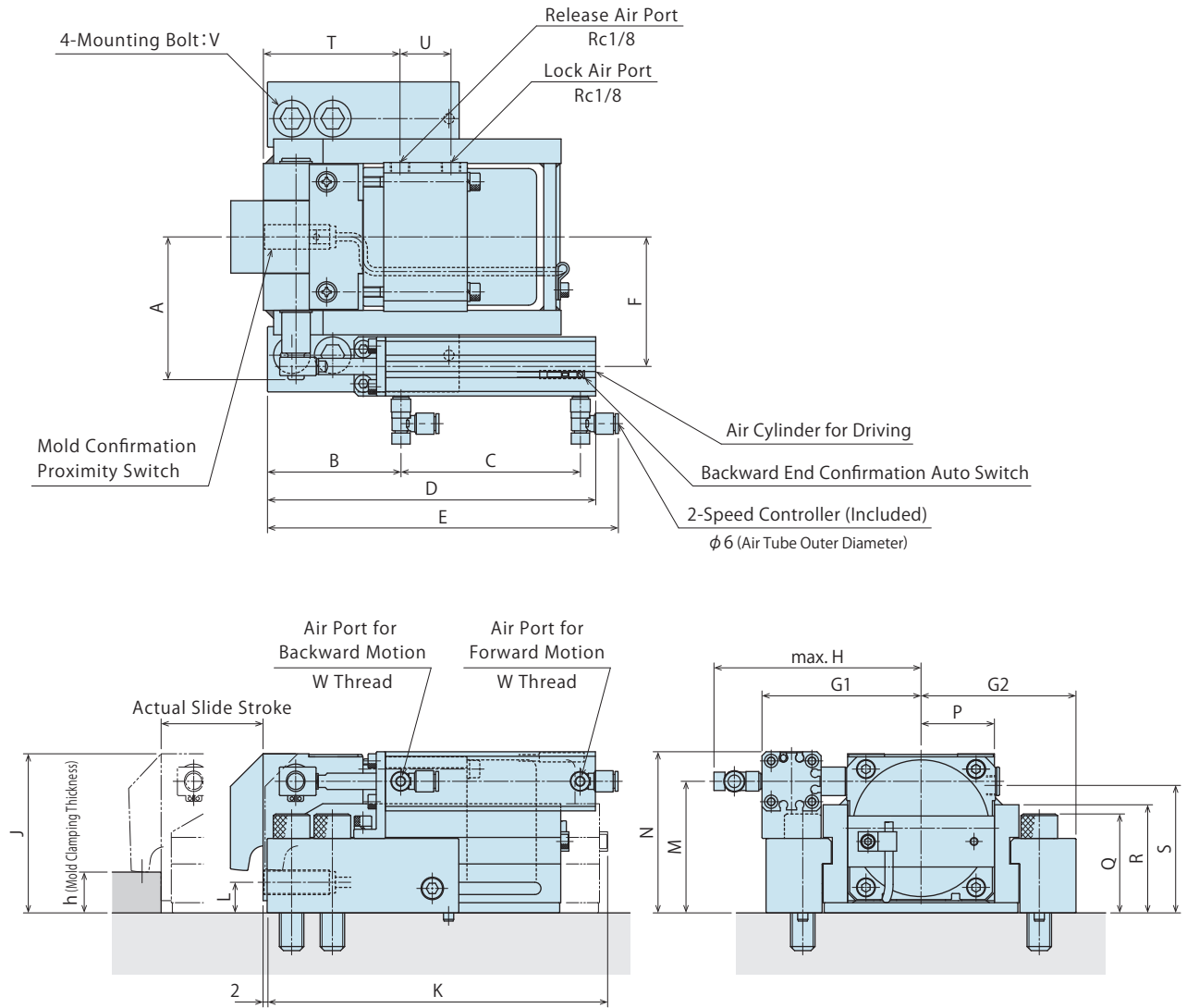

External Dimensions

(mm)

Model No.	QR0100	QR0160	QR0250	QR0400	QR0630	
QM Clamp Model No.	QM0100	QM0160	QM0250	QM0400	QM0630	
Full Stroke	2.6	2.8	3.4	4.3	4.6	
Clamp Stroke	0.6	0.6	0.6	0.6	0.8	
Extra Stroke	2	2.2	2.8	3.7	3.8	
A	54.5	60	70	94	113	
B	61	60.5	65.5	84	113.5	
C	69.5	76	88	112	153	
D	140.5	144	161	205	278.5	
E	149.1	155.1	172.1	214.6	285.6	
F	48	53.5	63.5	84	100.5	
G1	60	66	78	104	133	
G2	53	64.5	76	96	121.5	
H	83.6	89.6	101.6	127.6	146.9	
J	56	66	78	98	120.5	
K	130.7	145.7	167	205	240.5	
L	10	10	15	15	15	
M	47	55	64.5	80.5	98	
N	54.5	67.5	79	100.5	117.8	
P	31	34	36.5	44.5	55	
Q	33.5	40	48.5	58	73.5	
R	35.5	43.5	53	63	77	
S	45	53	62.5	78	96	
T	56	61	67	79	93	
U	21	22	25	36	42	
V (Nominal × Pitch × Length)	M8×1.25×40	M10×1.5×45	M12×1.75×55	M14×2×65	M20×2.5×85	
W (Nominal × Pitch)	M5×0.8	M5×0.8	M5×0.8	M5×0.8	Rc1/8	
Mold Clamping Thickness	min. h	15±0.3	15±0.3	20±0.3	25±0.3	30±0.3
	max. h	35±0.3	40±0.3	45±0.3	55±0.3	65±0.3

Notes :

1. Please refer to QM clamp pages for unlisted dimensions.
2. The accuracy of the mold clamping thickness (h dimension) should be within ±0.3mm.

Specifications : Proximity Switch

Proximity Switch Model No.	FL7M-7J6HD-L5	FL7M-7T7HD-L5
Manufacturer	Azbil	Azbil
Voltage	DC10~30V	AC100V / AC200V
Internal Voltage Drop	3V or less	10V or less
Load Current	3~100mA	5~100mA

Specifications : Auto Switch

Auto Switch Model No.	D-A93L	
Manufacturer	SMC	
Voltage	DC24V	AC100V
Internal Voltage Drop	3V or less	2.4V or less
Load Current	5~40mA	5~20mA

Model No. Indication

MV90 1 2 - UUSS - 5 - 4 - N

1
 2
 3
 4
 5

1 Design No.

2 : Revision Number

4 Operating Air Pressure

4 : 0.4MPa

2 Circuit Symbol ^{※1}

U : Clamp Circuit (With Pressure Switch)
(Solenoid Valve:2 Position Double)

S : Slider Circuit (Without Pressure Switch)
(Solenoid Valve:3 Position Exhaust Center)

T : Slider Circuit (Without Pressure Switch)
(Solenoid Valve:2 Position Double)

5 Option

Blank : Standard

C : – Common

K : Air Pressure Gauge with Color Range

N : NPT Thread ^{※2}

P : Air Pressure Gauge in both PSI/MPa

S : Solenoid Valve with Light/Surge Voltage Suppressor

3 Control Voltage

1 : AC100V

2 : AC200V

5 : DC24V

Notes :

- ※1. Air Valve Unit might be made to order depending on **2** Circuit Symbol.
Please contact us for delivery time before making an order.
- ※2. For **5** Option **N** : NPT Thread, the dimensions in the specification sheet and other documents are in Inches.

Specifications

Model No.		MV9012
Valve		Metal Seal / Five-Port Pilot Operated
Position	When Selecting 2 U, T	Two-Position Double Solenoid
•Number of Solenoid	When Selecting 2 S	Three-Position Exhaust Center
Piping Port Size	P Port	Rc1/4
	A/B Port	Rc1/4
Effective Cross Section Area	mm ²	15
Usable Fluid		Dry Air
Max. Clamp Operating Air Pressure	MPa	0.8
Min. Incoming Air Pressure	MPa	0.4
Withstanding Pressure	MPa	1.0
Usable Fluid Temperature	°C	-10 ~ +60
Oil Supply		No Oil Supply
Protection		Dust-Proof

● Circuit Symbol (Reference)

Circuit Symbol	Circuit Type	Applicable Clamp for Reference	
U	Clamp Circuit × 1 Circuit	Vertical Molding Machine	Upper Mold Only
		Horizontal Molding Machine	Stationary Platen / Movable Platen Simultaneous Operation
UU	Clamp Circuit × 2 Circuits	Horizontal Molding Machine	Stationary Platen / Movable Platen
UUU	Clamp Circuit × 3 Circuits	Vertical Molding Machine	Upper Mold One Circuit / Lower Mold Two Circuits
UUSS	Clamp Circuit × 2 Circuits Slider Circuit × 2 Circuits	Horizontal Molding Machine	Stationary Platen / Movable Platen

Air
Clamp System

Air Clamp

Air Valve Unit

Operation Panel
Control Unit

Cautions

● Circuit Diagram (Reference)

Circuit Symbol : UU

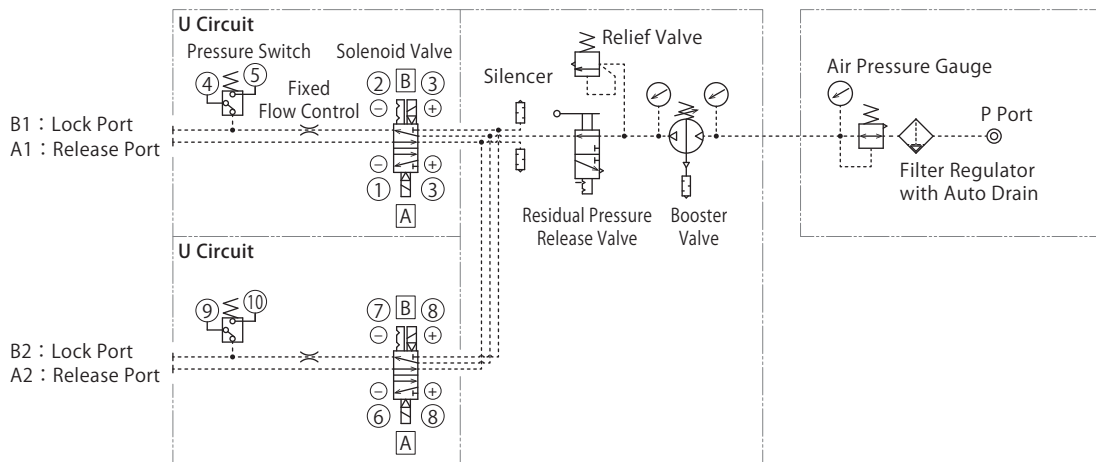

Circuit Symbol : UUSS

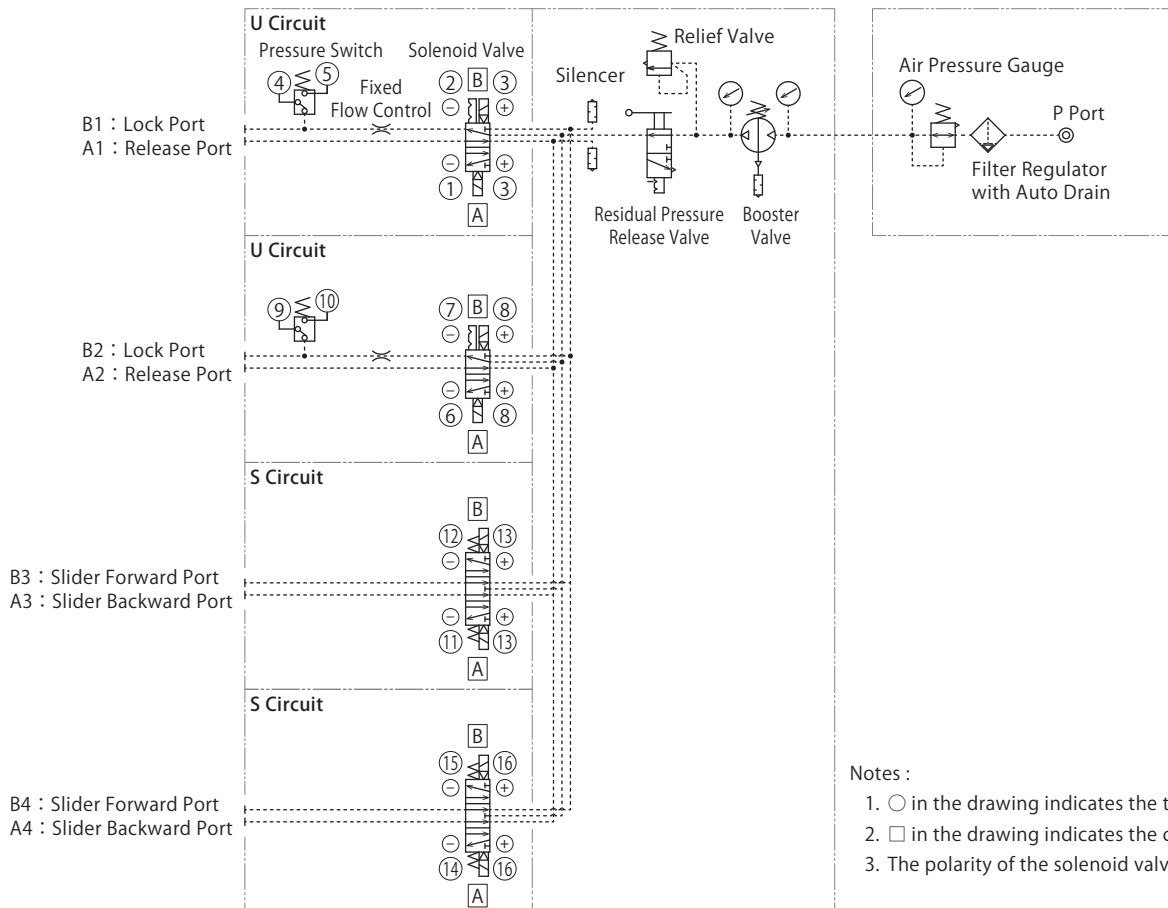

Notes :

- in the drawing indicates the terminal number.
- in the drawing indicates the coil number.
- The polarity of the solenoid valve is DC24V only.

External Dimensions

※ This drawing shows the standard model of MV9012-UU.

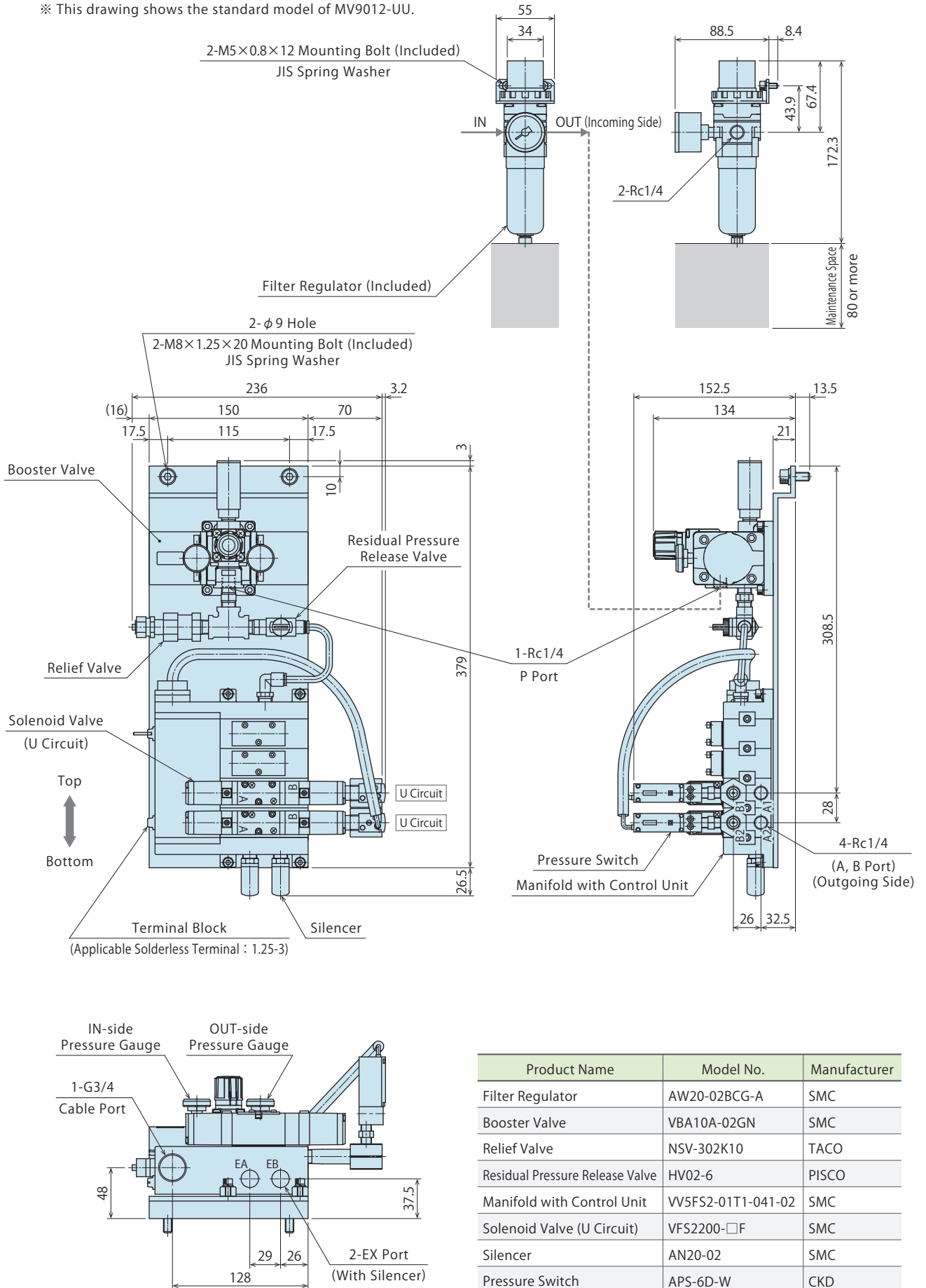

Product Name	Model No.	Manufacturer
Filter Regulator	AW20-02BCG-A	SMC
Booster Valve	VBA10A-02GN	SMC
Relief Valve	NSV-302K10	TACO
Residual Pressure Release Valve	HV02-6	PISCO
Manifold with Control Unit	VV5FS2-01T1-041-02	SMC
Solenoid Valve (U Circuit)	VFS2200-□F	SMC
Silencer	AN20-02	SMC
Pressure Switch	APS-6D-W	CKD

Notes :

1. Follow the top and bottom directions when mounting.
2. Pipe fittings to connect the filter regulator and the booster valve are prepared by customer.
3. Use a residual pressure release valve when bleeding outgoing pressure for maintenance or other reasons. (When operating a clamp, the valve must be closed.)

External Dimensions

※ This drawing shows the standard model of MV9012-UUSS.

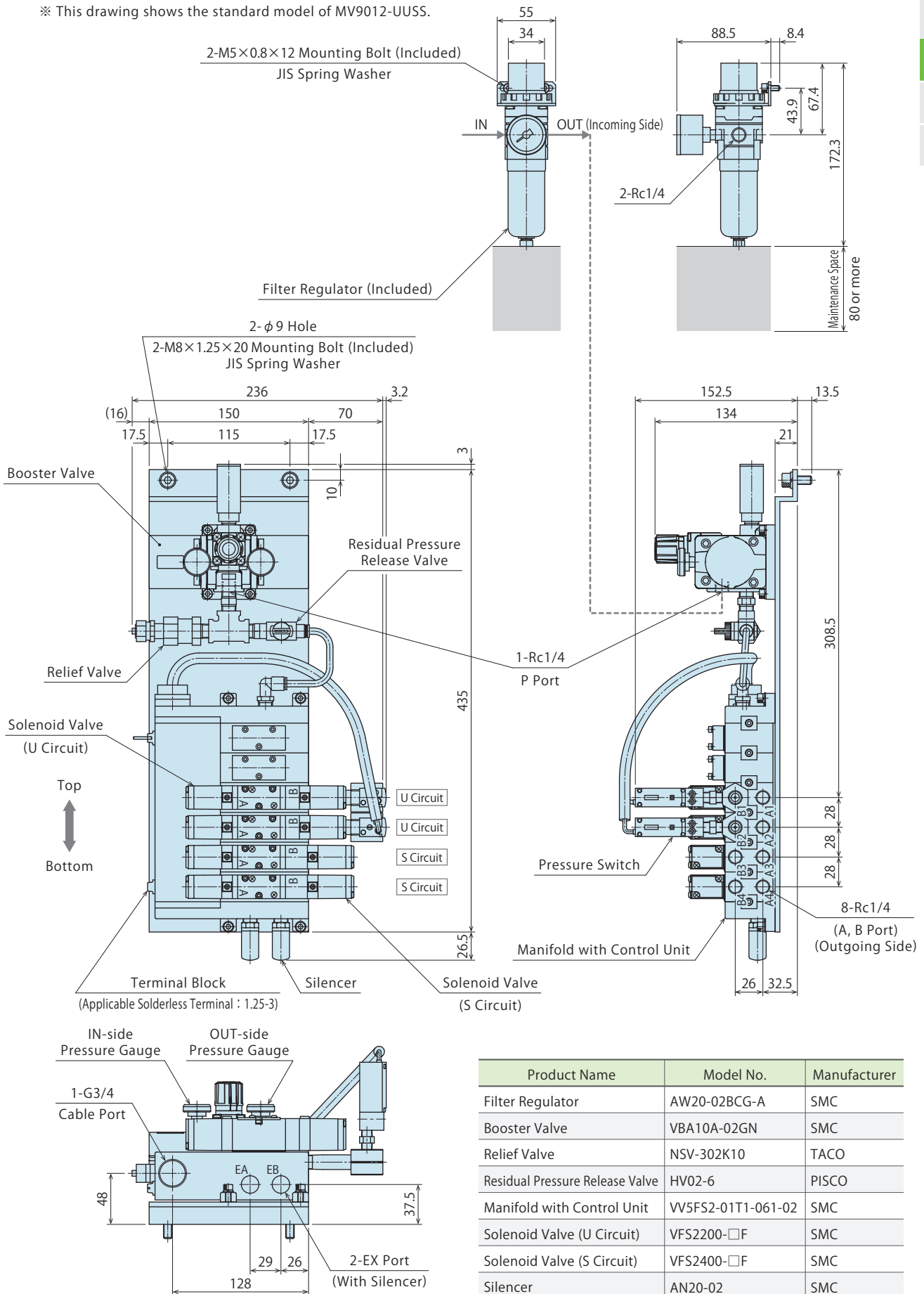

- Air Clamp System
- Air Clamp
- Air Valve Unit**
- Operation Panel Control Unit
- Cautions

Notes :

1. Follow the top and bottom directions when mounting.
2. Pipe fittings to connect the filter regulator and the booster valve are prepared by customer.
3. Use a residual pressure release valve when bleeding outgoing pressure for maintenance or other reasons. (When operating a clamp, the valve must be closed.)

Product Name	Model No.	Manufacturer
Filter Regulator	AW20-02BCG-A	SMC
Booster Valve	VBA10A-02GN	SMC
Relief Valve	NSV-302K10	TACO
Residual Pressure Release Valve	HV02-6	PISCO
Manifold with Control Unit	VV5FS2-01T1-061-02	SMC
Solenoid Valve (U Circuit)	VFS2200-□F	SMC
Solenoid Valve (S Circuit)	VFS2400-□F	SMC
Silencer	AN20-02	SMC
Pressure Switch	APS-6D-W	CKD

Operation Panel / Control Unit

Model YMC

Model YMV



Clamping System Controls for All Mold Change Methods

PAT.P

Model No. Indication

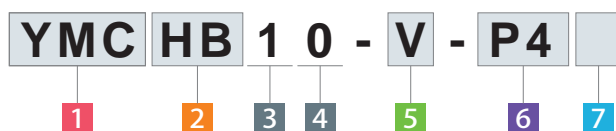

1 Operation Unit

YMC : Horizontal Molding Machine

YMV : Vertical Molding Machine

2 Applicable Clamp Model No.

HB : QB / QM Clamp

HE : QE / QR Clamp

3 Pressure Source

1 : With Pressure Switch in the Clamp Circuit
(When using MV Air Valve Unit)

4 Design No.

Revision Number

5 Machine type and Mold Loading/Unloading Direction

1 YMC: Horizontal Molding Machine

V : Horizontal Molding Machine•Vertical Loading

H : Horizontal Molding Machine•Horizontal Loading

1 YMV: Vertical Molding Machine

A : Vertical Molding Machine•Upper Mold Only

B : Vertical Molding Machine•Upper and Lower Mold

R□ : Vertical Rotary Machine (Lower Side)•Upper Mold ×1 Lower Mold ×2
Lower Side Rotary Table Stop Position

R1:1 Position / **R2**:2 Positions / **R3**:3 Positions / **R4**:4 Positions

6 Option

Blank : None

S2~S8 : With Mold Confirmation Proximity Switch (Series connection)
2-8 pcs. on each side

(**2** Applicable Clamp Model No. **HE** only)

P2~P8 : With Mold Confirmation Proximity Switch (Individual connection)
2-8 pcs. on each side

(**2** Applicable Clamp Model No. **HB** only)

F : Clamp Incomplete Detection

(**2** Applicable Clamp Model No. **HE** only)

W : Remote Monitoring System^{※1}

L : Without Locating Pin + With Release Confirmation Output^{※2}

※1. Please contact us for details of Option **W**.

※2. Option **L** can be selected only for horizontal mold loading.

7 Indication Language

Blank : Japanese

N : English

C : Chinese

Specifications

Model No.	YMC□10	
Control Panel Operating Voltage	DC24V (Supplied with the attached power supply.)	
Attached Power Supply	Input Voltage	AC100V~240V (50/60Hz)
	Output Capacity	30W

Notes :

1. Requested specifications other than those written above will be treated as custom made.
2. Signals are sent and received via dry contacts.
3. The molding machine output contact should be for fine current (DC24V / 10mA).
4. The output contact of Operation Panel/Control Unit is DC24V/0.5A.
5. Molding machine terminology may differ depending on the manufacturer.

Detail : Operation Panel

- (G) Display Light : Yellow Green
- (A) Display Light : Orange
- (R) Display Light : Red
- (W) Display Light : White

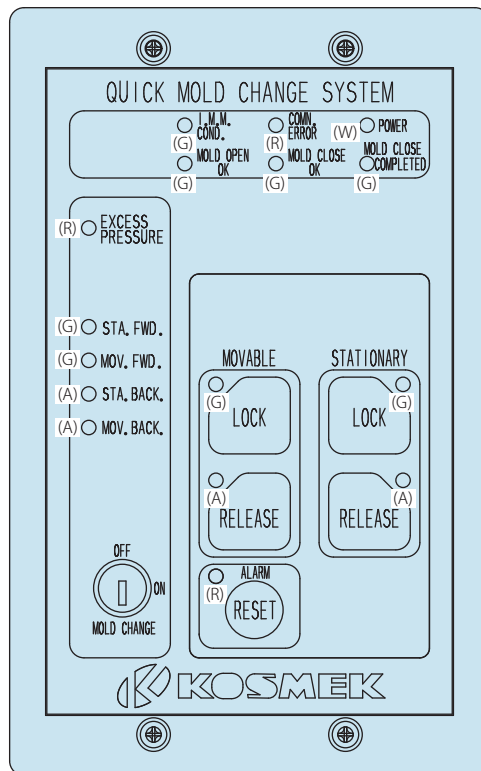

Detail : Control Unit

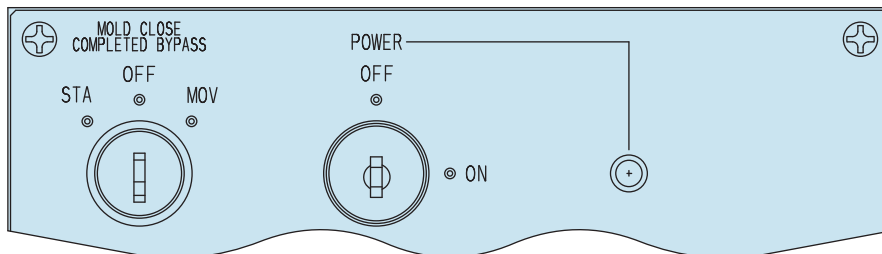

External Dimensions : Operation Panel

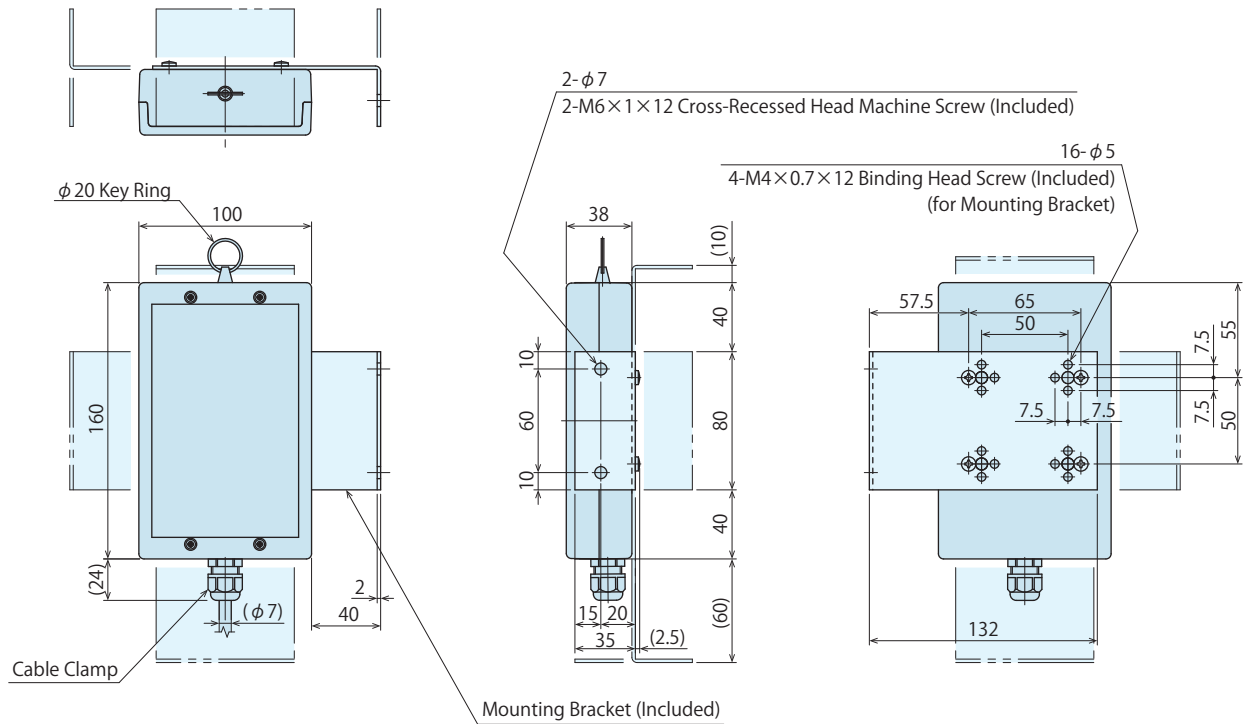

External Dimensions : Control Unit

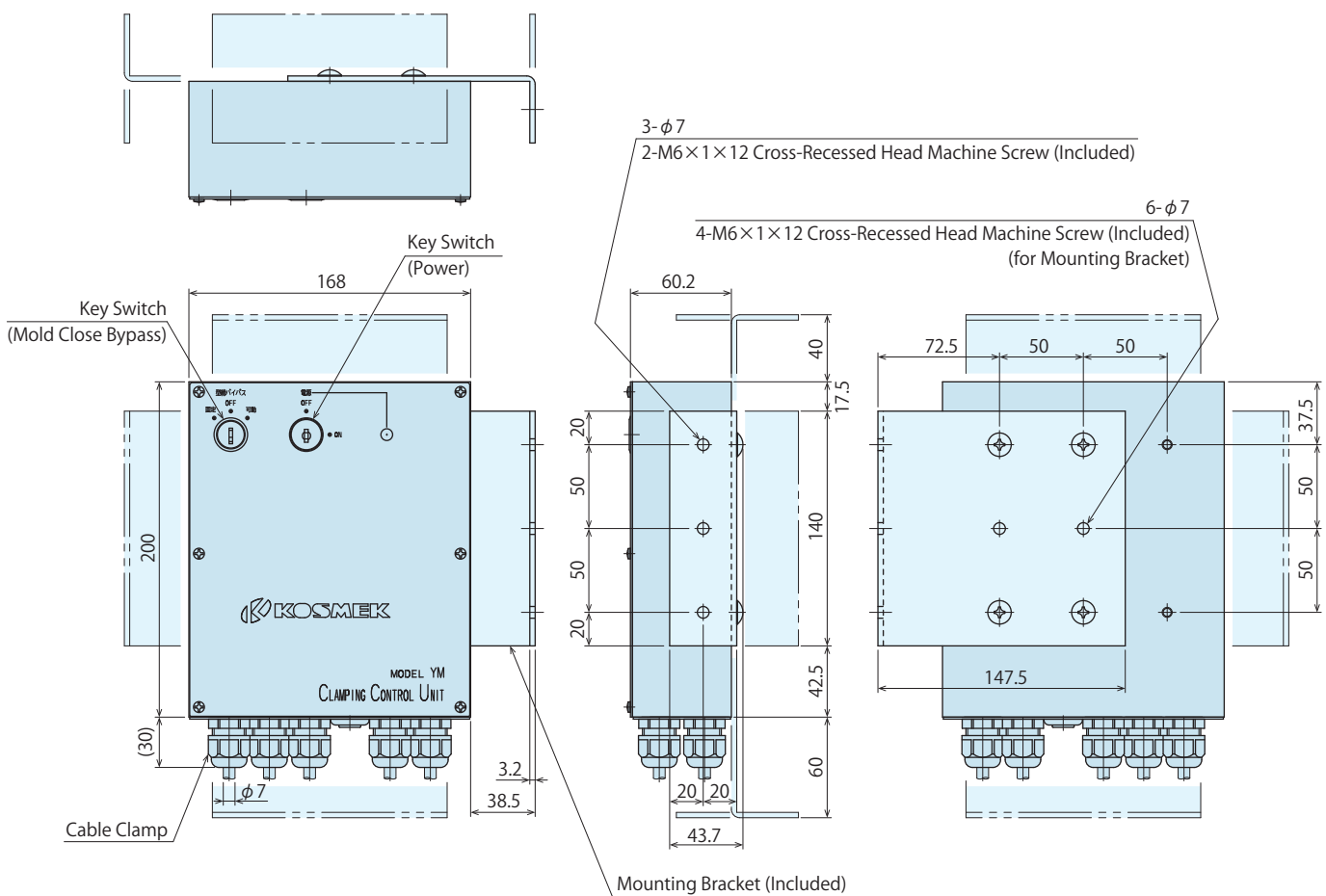

Note :

1. The bracket can be mounted in any direction.

Operation Procedure : For YMCHE10-V

※ Please contact us for the operation procedure for other models.

Clamp Operating Condition

Injection Molding Machine Condition				Clamp Operation Panel
Operation Mode :	Mold	Nozzle Back	Ejector Back	Mold Change "ON"
Mold Change	Close	(Option)	(Option)	

Note : 1. When the mold change switch is "ON", clamp error does not occur regardless of the condition of clamps during mold change.

Unloading a Mold

Operation Procedure	Confirmation Items	Cautions
Prepare for mold change.		
Switch the IMM condition to "Nozzle Back" / "Ejector Back" etc. (Input Options)		
Support the mold with the crane.		Confirm the mold is securely hung and cables are not loose.
Switch the IMM to Mold Change Mode.	"IMM COND." light ON. 	
Turn ON the "Mold Change" switch of the clamp operation panel. 		The clamping system controller keys should be carefully controlled by the person in charge.
Close the platens.	"MOLD CLOSE COMPLETED" light ON. 	
Press the [Stationary] and [Movable] "Release" buttons of the clamp operation panel. 	"STA. BWD END" "MOV. BWD END" lights ON. "RELEASE" lights ON. 	
	"MOLD OPEN OK" light ON.	
Open the platens.		Operate with low speed or inching.
Unload the mold.		Make sure there is no abnormality on clamps and other devices in the platen after unloading the mold.

Loading a Mold

Operation Procedure	Confirmation Items	Cautions
Load the mold with the crane.		Confirm specifications of the mold before loading.
Close the platens.	"MOLD CLOSE COMPLETED" light ON. 	
Press the [Stationary] and [Movable] "Lock" buttons of the clamp operation panel. 	"STA. FWD END" "MOV. FWD END" lights ON. "LOCK" lights ON. 	
Turn OFF the "Mold Change" switch of the clamp operation panel. 	"Mold Open OK" "Mold Close OK" lights ON.	
Release the mold from crane.		Make sure there is no abnormality on clamps and other devices in the platen.

- Air Clamp System
- Air Clamp
- Air Valve Unit
- Operation Panel Control Unit
- Cautions

Interlock Input and Output

※ Please contact us for any specifications other than those described below (custom-made).

I. M. M. Output	Contents
Mold Change Mode	A signal that ensures the IMM is in low-speed Mold Change Mode.
Mold Closed (Pressurized)	A signal that ensures the mold is completely closed. Prohibit the release operation while the mold is open to prevent the mold from falling.
Nozzle Back	A signal that ensures the nozzle or the injection unit is fully back to prevent damage to the nozzle when unloading the mold.
Ejector Back	A signal that ensures the ejector is in the back position to prevent damage to the ejector when unloading the mold.
I. M. M. Input	Contents
Mold Open OK	A signal that indicates the clamping system is ready for mold opening.
Mold Close OK	A signal that indicates the clamping system is ready for mold closing.
Mold Change "ON"	A signal that indicates the clamp system is in "Mold Change Mode".
Clamp Error	When an error in the clamp circuit occurs, this signal is sent to make an emergency stop of the machine.
Pressure Request	This signal requests additional hydraulic pressure when necessary to lock or release the clamps in Mold Change Mode.

Cautions

Notes for Design

- 1) Check Specifications
 - Please use each product according to the specifications.
 - Operate within the specified condition. Failure to do so may result in damage on clamps, falling down of molds and injury.
 - The ambient operating temperature of clamp should be 0 ~ 70°C. (High Temperature Model : 0 ~ 120°C.)

2) Clamping Mold Thickness

- Check the clamping mold thickness.

Clamping Mold Thickness of QB / QE Clamp :
 $h \pm 0.2\text{mm}$ (QB/QE0100 ~ QB/QE0250)
 $h \pm 0.3\text{mm}$ (QB/QE0400, QB/QE0630)

Clamping Mold Thickness of QM / QR Clamp :
 $h \pm 0.3\text{mm}$ (QM/QR0100 ~ QM/QR0630)

3) Allowable Protrusion Amount of Cylinder [QB / QE Clamp Only]

- Do not exceed the allowable protrusion amount. Otherwise, excessive force is applied to the clamp, deforming or dropping the clamp out of T-slot and resulting in falling off of mold and injury.

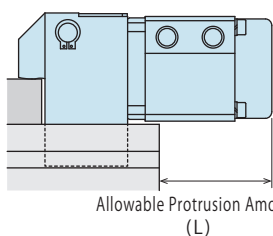

Allowable Protrusion Amount (L)

Allowable Protrusion Amount	
Model No.	L (mm)
QB0100	66
QB0160	73
QB0250	85
QB0400	105
QB0630	121

Allowable Protrusion Amount	
Model No.	L (mm)
QE0100	56
QE0160	63
QE0250	74
QE0400	90
QE0630	81

4) Clamp Mounting Position [QM / QR Clamp Only]

- If a guide block is protruded from the platen surface, excessive force is applied to the clamp which deforms or damages the clamp resulting in falling off of the mold and injury.

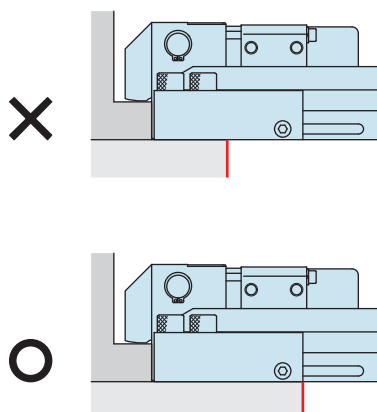

- 5) Clamping surface must be parallel to the IMM platen.
 - If clamping surface is not even or parallel, excessive force is applied to the clamp which deforms or damages the clamp resulting in falling off of the mold and injury.

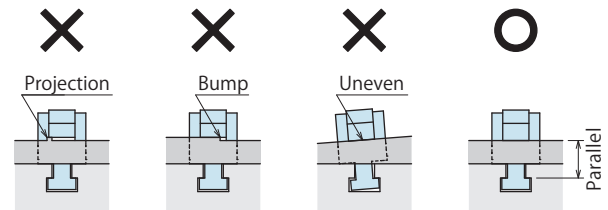

6) Interlock

- Make sure to control with the interlock so that clamps lock or release only when IMM is at mold close (pressurized) state.

7) Please supply filtered clean dry air.

8) Forward-End Confirmation Switch

- Proximity switch is used for forward-end confirmation. Make sure a mold surface on the switch side has no U-cut.

● Installation Notes

- 1) Please supply filtered clean dry air.
- 2) Procedure before Piping
 - The pipeline, piping connector, etc. should be cleaned and flushed thoroughly. The dust and cutting chips in the circuit may lead to fluid leakage and malfunction. (There is no filter provided with this product for prevention of contaminants in the air circuit.)
- 3) Applying Sealing Tape
 - Wrap with tape 1 to 2 times following the screwing direction. When piping, be careful that contaminants such as sealing tape do not enter in products. Pieces of the sealing tape can lead to air leaks and malfunction.
- 4) Mounting the Clamp 【QE Clamp Only】
 - After setting the clamp in the T-slot, use attached hex. socket bolts and tighten it with the torque shown below.

Model No.	Bolt Size	Tightening Torque (N·m)
QE0100	M5×0.8	6.3
QE0160	M5×0.8	6.3
QE0250	M5×0.8	6.3
QE0400	M6×1	10
QE0630	M8×1.25	25

- 5) Mounting the Clamp 【QM / QR Clamp Only】
 - Use attached hex. socket bolts and tighten it with the torque shown below.

Model No.	Bolt Size	Tightening Torque (N·m)
QM/QR0100	M8×1.25	25
QM/QR0160	M10×1.5	50
QM/QR0250	M12×1.75	80
QM/QR0400	M14×2	125
QM/QR0630	M20×2.5	400

- 6) Supplying Air Pressure with Coupler
 - When supplying air pressure with coupler, it is better to change the color of tube or coupler type in order not to connect lock air and release air opposite to each other.
- 7) Clamp Moving Speed
 - Please adjust the moving speed of the clamp with speed controllers to fully stroke within 1 to 2 seconds.

Cautions

Notes on Handling

- 1) Close the mold after molding is completed.
 - Failure to do so may result in mold dropping and injury.
- 2) Do not disassemble or modify the air cylinder.
 - Built-in spring is very strong and can be dangerous. If the equipment is taken apart or modified, the warranty will be voided even within the warranty period.
- 3) Do not remove the stopper pin.
 - The clamp may fall off from the guide block.

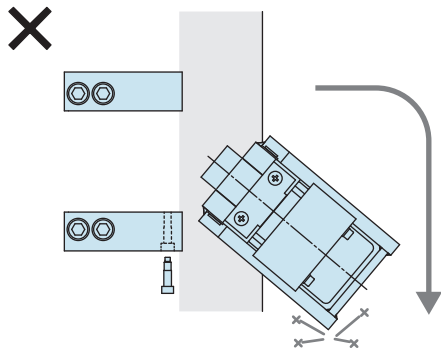

- 4) It should be handled by qualified personnel.
 - The hydraulic/pneumatic equipment should be handled and maintained by qualified personnel.
- 5) Do not handle or remove the product unless the safety protocols are ensured.
 - ① The machine and equipment can only be inspected or prepared when it is confirmed that the preventive devices are in place.
 - ② Before the product is removed, make sure that the above-mentioned safety measures are in place. Shut off the air of hydraulic source and make sure no pressure exists in the air circuit.
 - ③ After stopping the product, do not remove until the equipment cools down.
 - ④ Make sure there is no abnormality in the bolts and respective parts before restarting the machine or equipment.
- 6) Do not apply load on the clamp at 0MPa.
 - In case of air source trouble, the clamp has holding force with mechanical lock even when air pressure is at 0MPa. However, do not apply load on the clamp at this state.
- 7) Do not supply lock and release air pressure simultaneously.
 - It leads to damage and decline of the clamp capacity.

- 8) When positioning the clamp to the mold.
 - When positioning the clamp to the mold, make sure to hold and move the clamp until it touches the mold end surface. Holding or pulling on the air tube will lead to air leaks and malfunction due to damage on air tube and piping, etc. Also, clamping without the clamp touching the mold end surface will cause breakage of the clamp lever and mold.
 - Lock and release the clamp after connecting/disconnecting the coupler to make sure that the clamp operates properly.

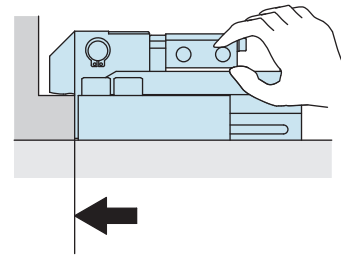

- 9) Supplying Air Pressure with Coupler
 - Make sure not to connect lock air and release air opposite to each other when supplying air pressure by connecting/disconnecting the coupler.
 - Lock and release the clamp after connecting/disconnecting the coupler to make sure that the clamp operates properly.
- 10) Do not touch clamps while they are working.
 - Otherwise, your hands may be injured.

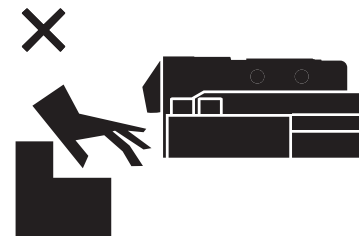

- 11) Please hold the main body of the clamp when removing it.
 - If pulling on the air tube, the clamp will fall off leading to injury. Also, the air tube and piping will be damaged leading to air leakage.

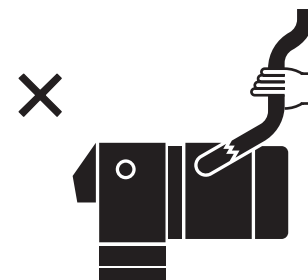

- 12) Do not pour water / oil over the product.
 - It may lead to malfunction or deterioration of the product and cause an accident.



● Maintenance and Inspection

- 1) Removal of the Product and Shut-off of Pressure Source
 - Before the product is removed, make sure that the safety measures mentioned earlier are in place. Shut off the air of hydraulic source and make sure no pressure exists in the air circuit. Also make sure there is no abnormality in the bolts and respective parts before restarting.
- 2) Regularly tighten piping to ensure proper use.
- 3) Periodically ensure that supply air pressure is a specified value.
- 4) Make sure to supply filtered clean dry air.
- 5) Make sure there is smooth action and no abnormal noise. (When the product is restarted after left unused for a long period, make sure it operates properly.)
- 6) The products should be stored in the cool and dark place without direct sunshine or moisture.
- 7) Please contact us for overhaul and repair.
- 8) Loosen the stopper pin when removing the clamp body from the guide block for maintenance or other reasons.
【QM/QR Clamp Only】

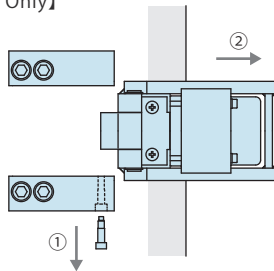

When using it again, make sure to tighten the stopper pin.

● Warranty

- 1) Warranty Period
 - The product warranty period is 18 months from shipment from our factory or 12 months from initial use, whichever is earlier.
- 2) Warranty Scope
 - If the product is damaged or malfunctions during the warranty period due to faulty design, materials or workmanship, we will replace or repair the defective part at our expense. Defects or failures caused by the following are not covered.
 - ① If the stipulated maintenance and inspection are not carried out.
 - ② If the product is used while it is not suitable for use based on the operator's judgment, resulting in defect.
 - ③ If it is used or handled in inappropriate way by the operator. (Including damage caused by the misconduct of the third party.)
 - ④ If the defect is caused by reasons other than our responsibility.
 - ⑤ If repair or modifications are carried out by anyone other than Kosmek, or without our approval and confirmation, it will void warranty.
 - ⑥ Other caused by natural disasters or calamities not attributable to our company.
 - ⑦ Parts or replacement expenses due to parts consumption and deterioration. (Such as rubber, plastic, seal material and some electric components.)

Damages excluding from direct result of a product defect shall be excluded from the warranty.

Quick Ejector Rod

model PME

The ejector rod has been divided into a base rod and an attachment rod for **speed, simplicity** and **ease-of-use** when changing ejector patterns. No tools are required, allowing **changes in mere seconds**.

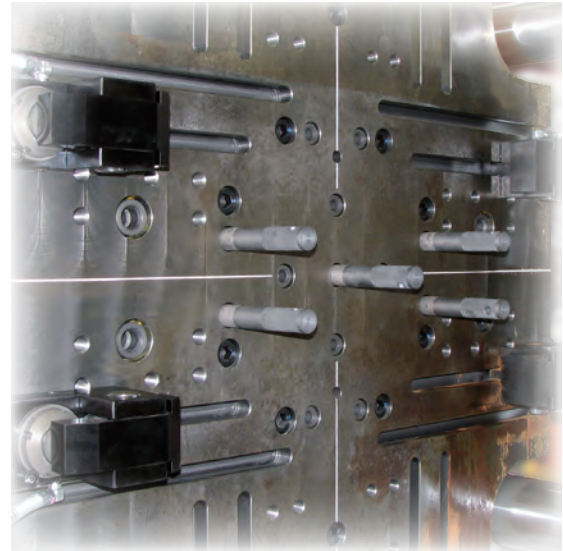

Changing Ejector Rods

Move the ejector plate fully forward.

Pull out the attachment rods by hand.

Arrange them in the new pattern.

Ejector rod pattern change in seconds !

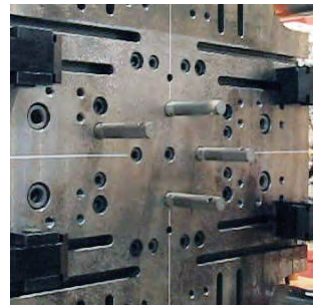
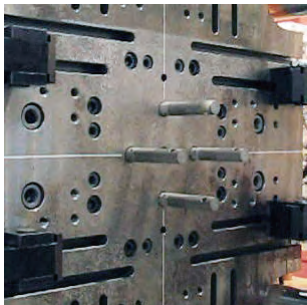

Exchange Start

2 sec. Progress

4 sec. Progress

Completed in 5 sec. ※1

※1. The changing time varies with molding machine size, ejector rod length, work environment, or else.

For quick ejector rod details, please contact your KOSMEK representative, visit the KOSMEK website at [<http://www.kosmek.com>], or refer to the quick ejector rod catalog.



KOSMEK LTD.

<http://www.kosmek.com/>

HEAD OFFICE 1-5, 2-chome, Murotani, Nishi-ku, Kobe-city, Hyogo, Japan 651-2241
TEL.+81-78-991-5162 FAX.+81-78-991-8787

United States of America SUBSIDIARY	KOSMEK (USA) LTD. 650 Springer Drive, Lombard, IL 60148 USA TEL. +1-630-620-7650 FAX. +1-630-620-9015
MEXICO REPRESENTATIVE OFFICE	KOSMEK USA Mexico Office Av. Santa Fe 103, Int. 59, col. Santa Fe Juriquilla, Queretaro, QRO, 76230, Mexico TEL. +52-1-55-3044-9983
EUROPE SUBSIDIARY	KOSMEK EUROPE GmbH Schleppeplatz 2 9020 Klagenfurt am Wörthersee Austria TEL. +43-463-287587 FAX. +43-463-287587-20
CHINA SUBSIDIARY	KOSMEK (CHINA) LTD. Room601, RIVERSIDE PYRAMID No.55, Lane21, Pusan Rd, Pudong Shanghai 200125, China TEL. +86-21-54253000
INDIA BRANCH OFFICE	KOSMEK LTD. - INDIA 4A/Old No:649, Ground Floor, 4th D cross, MM Layout, Kavalbyrasandra, RT Nagar, Bangalore -560032 India TEL.+91-9880561695
THAILAND REPRESENTATIVE OFFICE	KOSMEK Thailand Representation Office 67 Soi 58, RAMA 9 Rd., Phatthanakan, Suanluang, Bangkok 10250, Thailand TEL. +66-2-300-5132 FAX. +66-2-300-5133



WAHLTEC GmbH
T: +49 (7584) 9238883
F: +49 (7584) 9238887
kosmek@wahltec.de
www.wahltec.de

- For Further Information on Unlisted Specifications and Sizes, Please call us.
- Specifications in this Leaflet are Subject to Change without Notice.

