

Spring Loaded Mold Locator



PAT. P.

Locates Molds with Non-Standardized Heights!

Point! 1 By changing spacer blocks, one system can locate molds of various dimensions.

Point! 2 Mold locating bar lifts up during the mold change process and automatically locates the mold.

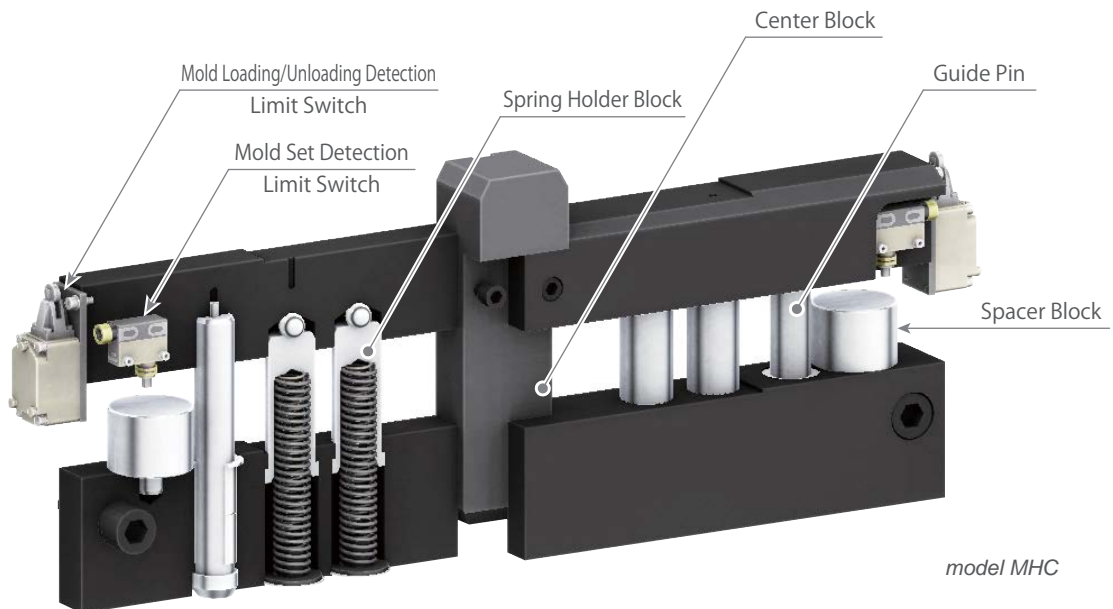

model MHC

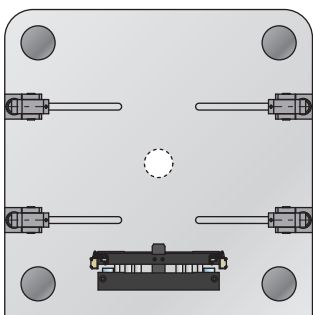

Springs lift the Mold Locator up when no mold is set.

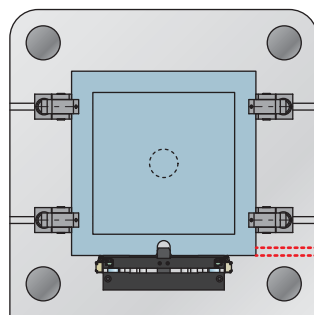

The Mold Locator detects when a mold is being loaded and when the mold is set into place. Interlocks with the IMM are available.

Easy to Locate Molds with Non-Standardized Mold Heights

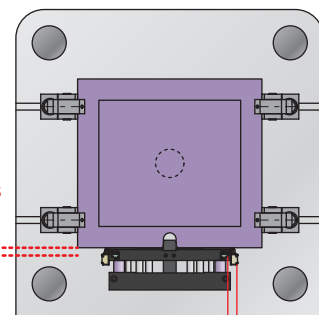

★ Mold Loading/Unloading Detection
★ Mold Set Detection

Mold Locator Systems are each specially designed to match the specifications of your application (tapped hole and T-slot pattern, mold weight and backplate dimensions, etc.).

Specifications : Main Body

| Model No. | MHC**** | |
|-----------------------|-----------------|---------------|
| IMM Capacity | kN | 13000 ~ 30000 |
| Slide Stroke | mm | 75 |
| Spring Force | N | 127 ~ 370 |
| Operating Temperature | °C | 0 ~ 70 |
| Use Frequency | 20 Cycles / Day | |

Specifications : Limit Switch

| Purpose | Mold Loading/Unloading Detection | Mold Landing Detection |
|-------------------|----------------------------------|------------------------|
| Model No. | 5LS1-JEC | SL1-H |
| Maker | Azbil | Azbil |
| Electrical Rating | AC125V - 5A | AC - 15 : 3A - 250V |
| | DC125V - 0.8A | AC - 12 : 5A - 250V |
| | - | DC - 12 : 2A - 48V |
| LED Light | With LED Light | - |

Note: Please contact us for specifications outside those listed above.

External Dimensions

- The below example shows the stationary platen side.
The Mold Locator is designed to the specifications of the IMM and the molds.

※1. Spacer block thickness. (Please indicate the spacer block thickness in 1mm increments.)

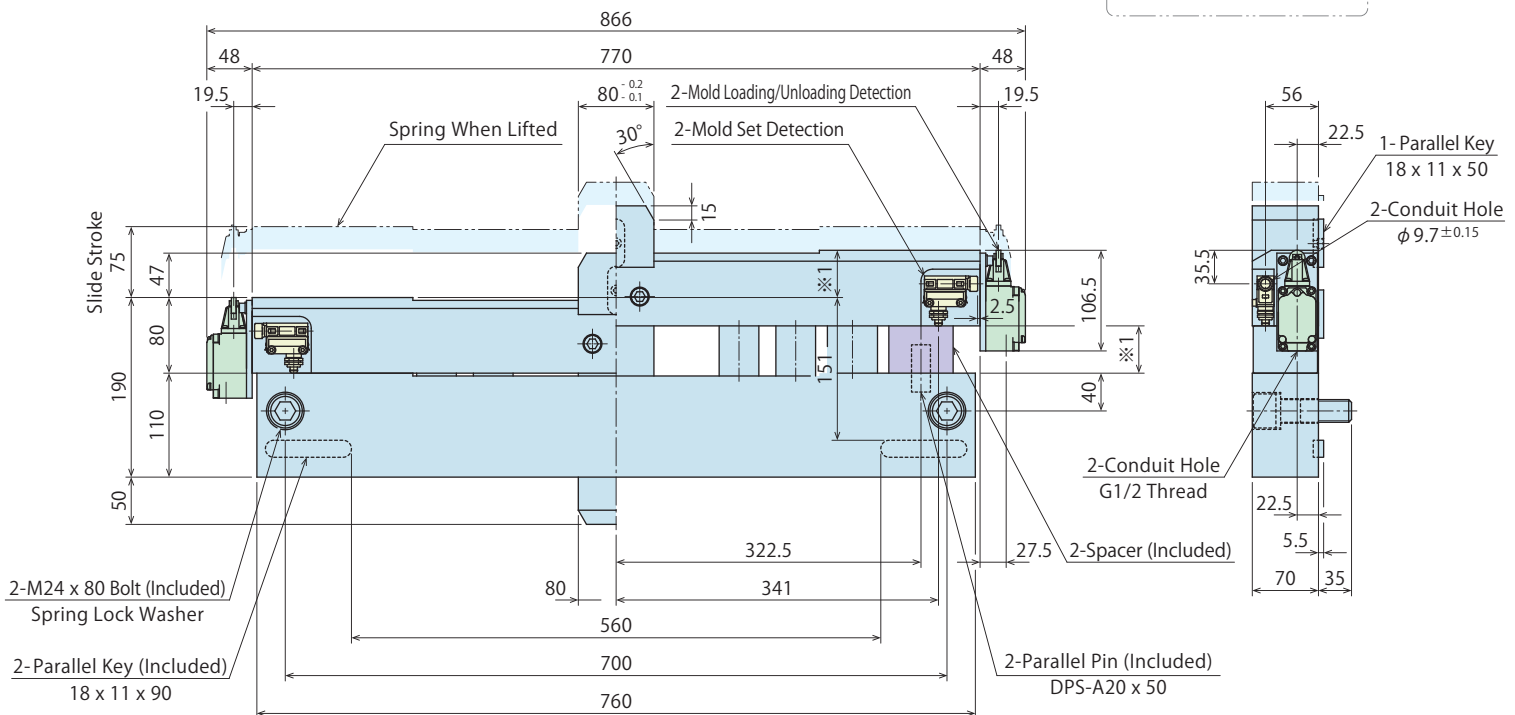
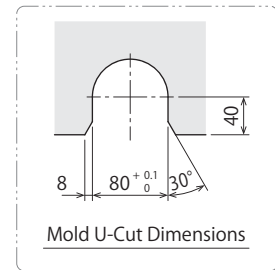

KOSMEK
Harmony in Innovation

| | |
|--|--|
| <p>KOSMEK LTD. KOSMEK (USA) LTD. KOSMEK (CHINA) LTD. KOSMEK LTD - INDIA Thailand Representative Office Full Life Trading Co., Ltd. G. E. T. Inc, Phil. KOS-MECH GmbH P. T PANDU HYDRO PNEUMATICS</p> | <p>1-5, 2-chome, Murotani, Nishi-ku, Kobe-city, Hyogo 6512241, Japan 1441 Branding Avenue, Suite 110, Downers Grove, IL 60515 USA 21/F, Orient International Technology Building, No.58, Xiangchen Rd, Pudong Shanghai 200122., P.R.China F 203, Level-2, First Floor, Prestige Center Point, Cunningham Road, Bangalore -560052 India 67 Soi 58, RAMA 9 Rd., Suanluang, Suanluang, Bangkok 10250, Thailand 16F-4, No.2, Jian Ba Rd., Zhonghe District, New Taipei City Taiwan 23511 Victoria Wave Special Economic Zone Mt. Apo Building, Brgy. 186, North Caloocan City, Metro Manila, Philippines 1427 Schleppplatz 2 9020 Klagenfurt Austria Ruko Green Garden Blok Z-II No.51 Rt. 005 Rw.008 Kedoya Utara-Kebon Jeruk Jakarta Barat 11520 Indonesia</p> |
|--|--|

WAHLTEC
KNOWLEDGE | TRUST | SUCCESS

WAHLTEC GmbH
Ravensburger Str. 14
88361 Altshausen
T: +49 (7584) 9238883
F: +49 (7584) 9238887

